

QUANTUM INFORMATION TECHNOLOGY: Entanglement, Teleportation, and Memory

Jeffrey H. Shapiro

Massachusetts Institute of Technology
Department of Electrical Engineering and Computer Science
Research Laboratory of Electronics
Laboratory for Information and Decision Systems

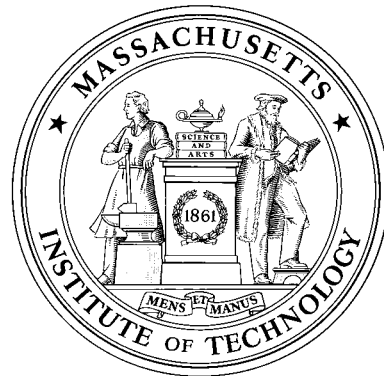

Presented at the Kick-Off Meeting of the ARO/DARPA
Quantum Communications & Quantum Memory Initiative
Fort Monmouth, NJ, June 13–14, 2000

QUANTUM INFORMATION TECHNOLOGY: Entanglement, Teleportation, and Memory

**Massachusetts Institute of Technology and Northwestern University
with Cooperation from the Air Force Research Laboratory**

A MULTIDISCIPLINARY UNIVERSITY RESEARCH INITIATIVE

- **MIT/NU PROGRAM TEAM**

- Principal Investigator: J.H. Shapiro (MIT)
- MIT: P.L. Hagelstein, S. Lloyd, M.S. Shahriar, M. Sudan, N.C. Wong
- NU: P. Kumar, H.P. Yuen
- AFRL Cooperation: P.R. Hemmer

- **MIT/NU PROGRAM ELEMENTS**

- TELEPORTATION USING SINGLET STATES
- QUADRATURE TELEPORTATION USING SOLITONS
- THEORETICAL STUDIES

QUANTUM INFORMATION TECHNOLOGY: Entanglement, Teleportation, and Memory

- **TELEPORTATION USING SINGLET STATES**
 - Classical Bits vs. Quantum Qubits
 - Qubit Teleportation
 - Long-Distance Quantum Communication System
 - Ultrabright Narrowband Entanglement Source
 - Trapped-Atom Quantum Memory
 - Loss-Limited Throughput/Fidelity Analysis
 - Compatibility with Standard Telecommunication Fiber
- **TELEPORTATION USING FIELD QUADRATURES**
 - Analog Information: Quadrature Components
 - Quadrature-Based Teleportation
 - Quadrature-Based Quantum Repeater Chain
 - Loss-Limited Fidelity Analysis
 - Soliton-Based Fiber-Optic Teleportation

CLASSICAL VS. QUANTUM INFORMATION

SUPERPOSITION AND ENTANGLEMENT

- **CLASSICAL ON-OFF SYSTEM STORES ONE BIT**
 - Off state = 0 and On state = 1
 - System must be in state 0 or state 1
- **QUANTUM TWO-LEVEL SYSTEM STORES ONE QUBIT**
 - Atom example: ground state = $|0\rangle$ and excited state = $|1\rangle$
 - Photon example: \uparrow -polarization = $|0\rangle$ and \bullet -polarization = $|1\rangle$
 - System can be in state $|\psi\rangle = \alpha|0\rangle + \beta|1\rangle$, with $|\alpha|^2 + |\beta|^2 = 1$
- **TWO CLASSICAL SYSTEMS CAN BE STATISTICALLY DEPENDENT**
 - $\Pr(\text{bit}_1, \text{bit}_2) \neq \Pr(\text{bit}_1) \Pr(\text{bit}_2)$
- **TWO QUANTUM SYSTEMS CAN BE ENTANGLED**
 - System can be in state $|\psi\rangle_{12} = (|0\rangle_1|1\rangle_2 - |1\rangle_1|0\rangle_2) / \sqrt{2}$

QUBIT TELEPORTATION USING SINGLET STATES*

- TRANSMITTER T AND RECEIVER R SHARE ENTANGLED QUBITS

$$|\psi\rangle_{TR} = (|0\rangle_T|1\rangle_R - |1\rangle_T|0\rangle_R) / \sqrt{2}$$

- TRANSMITTER ACCEPTS INPUT QUBIT $|\Psi\rangle_{in} = \alpha|0\rangle_{in} + \beta|1\rangle_{in}$

- TRANSMITTER/RECEIVER/INPUT STATE IN BELL BASIS:

$$\begin{aligned} |\Psi\rangle_{in}|\psi\rangle_{TR} &= (\alpha|0\rangle_R + \beta|1\rangle_R) (|1\rangle_{in}|0\rangle_T - |0\rangle_{in}|1\rangle_T) / \sqrt{8} \\ &+ (\alpha|0\rangle_R - \beta|1\rangle_R) (|1\rangle_{in}|0\rangle_T + |0\rangle_{in}|1\rangle_T) / \sqrt{8} \\ &+ (\alpha|1\rangle_R + \beta|0\rangle_R) (|1\rangle_{in}|1\rangle_T - |0\rangle_{in}|0\rangle_T) / \sqrt{8} \\ &- (\alpha|1\rangle_R - \beta|0\rangle_R) (|1\rangle_{in}|1\rangle_T + |0\rangle_{in}|0\rangle_T) / \sqrt{8} \end{aligned}$$

- BELL-STATE MEASUREMENTS MADE ON TRANSMITTER/INPUT
- TWO CLASSICAL BITS SENT TO RECEIVER
- SIMPLE TRANSFORMATION YIELDS $|\Psi\rangle_R = \alpha|0\rangle_R + \beta|1\rangle_R$

*C.H. Bennett, G. Brassard, C. Crépeau, R. Josza, A. Peres, and W.K. Wootters, "Teleporting an unknown quantum state via dual classical and Einstein-Podolsky-Rosen channels," Phys. Rev. Lett., vol. 70, pp. 1895–1899 (1993).

QUBIT TELEPORTATION USING SINGLET STATES

STATE OF THE ART*

- **INNSBRUCK TELEPORTATION EXPERIMENT: ACCOMPLISHMENTS**

- Teleportation Using Photons: Flying Qubits
- Polarization-Entanglement Generated via Parametric Downconversion
- Photodetection Used to Perform One of the Bell Measurements
- Photodetection Used to Verify Teleportation

- **INNSBRUCK TELEPORTATION EXPERIMENT: DRAWBACKS**

- Conditional Teleportation: Only One Bell State Measured
- Incompatible with Long-Distance Fiber-Optic Transmission
- No Long-Term Quantum Memory: No Mechanism for Standing Qubits

*D. Bouwmeester, J.-W. Pan, K. Mattle, M. Eibl, H. Weinfurter, and A. Zeilinger, “Experimental quantum teleportation,” *Nature*, vol. 390, pp. 575–579 (1997); D. Bouwmeester, K. Mattle, J.-W. Pan, H. Weinfurter, A. Zeilinger, and M. Zukowski, “Experimental quantum teleportation of arbitrary quantum states,” *Appl. Phys. B*, vol. 67, pp. 749–752 (1998).

QUBIT TELEPORTATION USING SINGLET STATES

MIT/NU QUANTUM COMMUNICATION PROPOSAL

- SINGLE-HOP CONFIGURATION

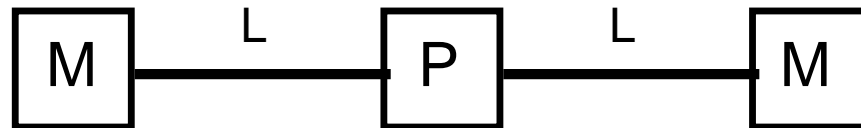

- TWO-HOP CONFIGURATION

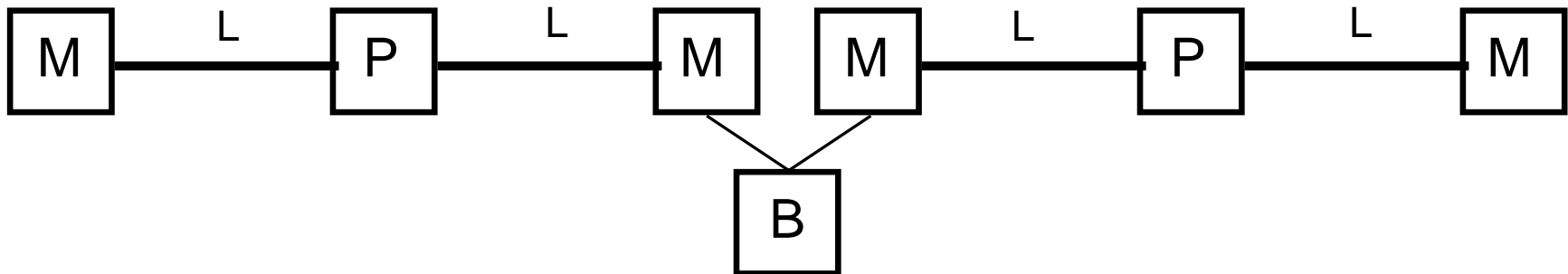

M = Trapped-Atom Quantum Memory

P = Source of Polarization-Entangled Photon Pairs

L = ≤ 25 km of Standard Telecommunication Fiber

B = Bell-State Measurement

QUBIT TELEPORTATION USING SINGLET STATES

Essential Components of Quantum Communication System

(a) ULTRABRIGHT NARROWBAND ENTANGLEMENT SOURCE

(b) SIMPLIFIED ATOMIC-LEVEL SCHEMATIC OF QUANTUM MEMORY

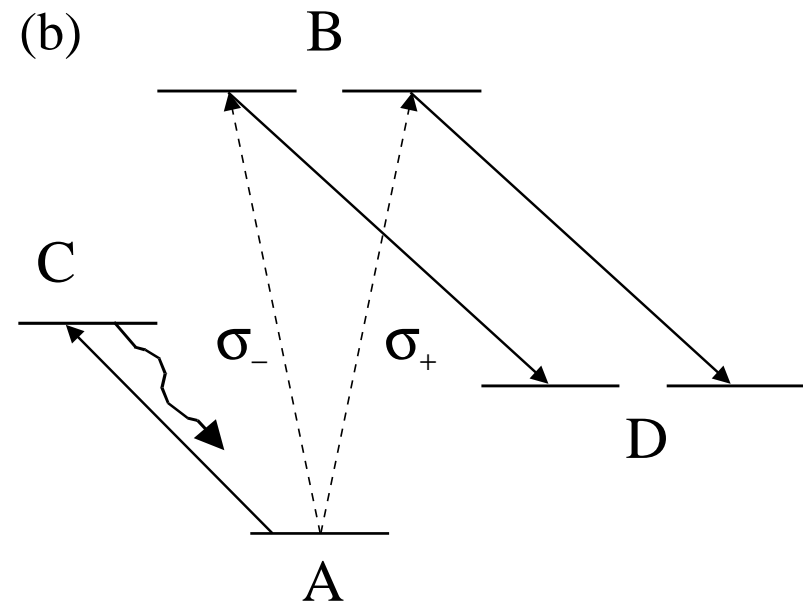
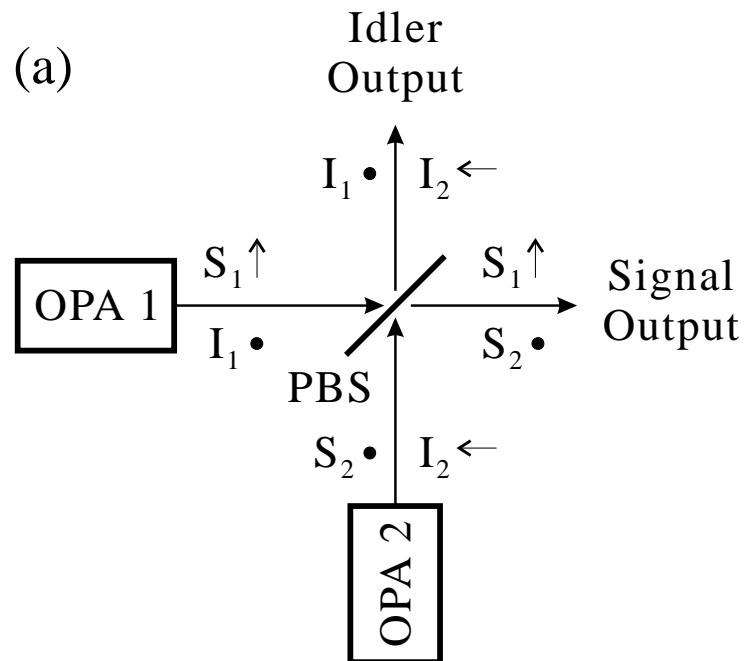

795 nm WAVELENGTH ^{87}Rb QUANTUM MEMORY*

- **NONDESTRUCTIVE VERIFICATION OF MEMORY LOADING**
 - Fluorescence Detection from *A-to-C* Cycling Transition
- **STORAGE TIME GREATLY EXCEEDS PROPAGATION DELAY**
 - Liquid He Cryostat (10^{-14} Torr) \rightarrow Decoherence Time > 1 Hour
- **ALL FOUR BELL-STATE MEASUREMENTS CAN BE MADE**
 - Uses Sequential Optically Off-Resonant Raman (OOR) Transitions
- **STATE TELEPORTATION IN MEMORY**
 - Needs at Most Two OOR Transitions for Completion
- **PHOTON RECOVERY FROM MEMORY**
 - Stored Qubit Conversion by Reversing the Raman Excitation

*S. Lloyd, M.S. Shahriar, and P.R. Hemmer, “Teleportation and the quantum Internet,” submitted to Phys. Rev. A. (<http://qop.mit.edu/papers/qunetfinal.pdf>)

ULTRABRIGHT NARROWBAND SOURCE OF POLARIZATION-ENTANGLED PHOTON PAIRS*

- **TRADITIONAL PARAMETRIC DOWNCONVERTER SOURCE**
 - Broadband: $\sim 10^{13}$ Hz
 - State of the Art: $\sim 1.5 \times 10^6$ pairs/sec in 3×10^{12} Hz
- **TRAPPED-ATOM QUANTUM MEMORY**
 - Narrowband: $\sim 10^7$ Hz
 - Downconverter Flux: ~ 15 pairs/sec in 3×10^7 Hz
- **DUAL OPTICAL PARAMETRIC AMPLIFIER (OPA) SOURCE**
 - Narrowband: $\sim 1.5 \times 10^6$ pairs/sec in 3×10^7 Hz
 - Selectable Wavelength via Quasi-Phase-Matched Nonlinear Materials
- **COMPATIBILITY WITH STANDARD TELECOMMUNICATION FIBER**
 - Transmission at $1.55 \mu\text{m}$ plus Frequency Upconversion to 795 nm
 - Time-Division Multiplexing to Compensate for Birefringence

*J.H. Shapiro and N.C. Wong, "An ultrabright narrowband source of polarization-entangled photon pairs," J. Opt. B, vol. 2, pp. L1–L4 (2000).

QUBIT TELEPORTATION USING SINGLET STATES

Memory Loading Protocol

- TRAPPED ATOMS INITIALLY IN NON-ABSORBING STATES
 - Physical Displacement or Optical Detuning
- SIGNAL AND IDLER TIME-SLOTS TRANSMITTED DOWN FIBER
 - ~ 400 nsec Duration
- COLD-CAVITY LOADING INTERVAL
 - ~ 400 nsec Duration
- ATOMS MOVED INTO ABSORBING STATES
 - Coherent Pumping of *B-to-D* Transition for ~ 100 nsec
- LOAD VERIFICATION VIA CYCLING TRANSITION
 - ~ 30 cycles ($\sim 1 \mu\text{sec}$) for High-Reliability Fluorescence Detection
- LOAD SUCCESS WHEN ENTANGLED PHOTON PAIR IS ABSORBED
 - Protocol Repeated Until Both Atoms Have Absorbed Photons

QUBIT TELEPORTATION USING SINGLET STATES

Figures of Merit

- CYCLING-RATE FOR MEMORY LOADING PROTOCOL: $R \sim 500$ kHz

- TAXONOMY OF LOADING-TRIAL OCCURRENCE POSSIBILITIES

$$P_{\text{erasure}} \equiv \text{Pr}(\text{At Most One Atom Absorbs a Photon})$$

$$P_{\text{success}} \equiv \text{Pr}(\text{Each Atom Absorbs Photon from the Same Entangled Pair})$$

$$P_{\text{error}} \equiv 1 - P_{\text{erasure}} - P_{\text{success}}$$

- SUCCESS-PROBABILITY LIMIT ON THROUGHPUT

$$N_{\text{success}} \equiv RP_{\text{success}} \text{ pairs/sec}$$

- ERROR-PROBABILITY LIMIT ON FIDELITY

$$F_{\text{max}} \equiv 1 - \frac{P_{\text{error}}/3}{P_{\text{success}} + P_{\text{error}}}$$

QUBIT TELEPORTATION USING SINGLET STATES

Figures of Merit

- CYCLING RATE $R = 500$ kHz
- FIBER LOSS 0.2 dB/km; FIXED LOSSES 5 dB PER P -TO- M LINK

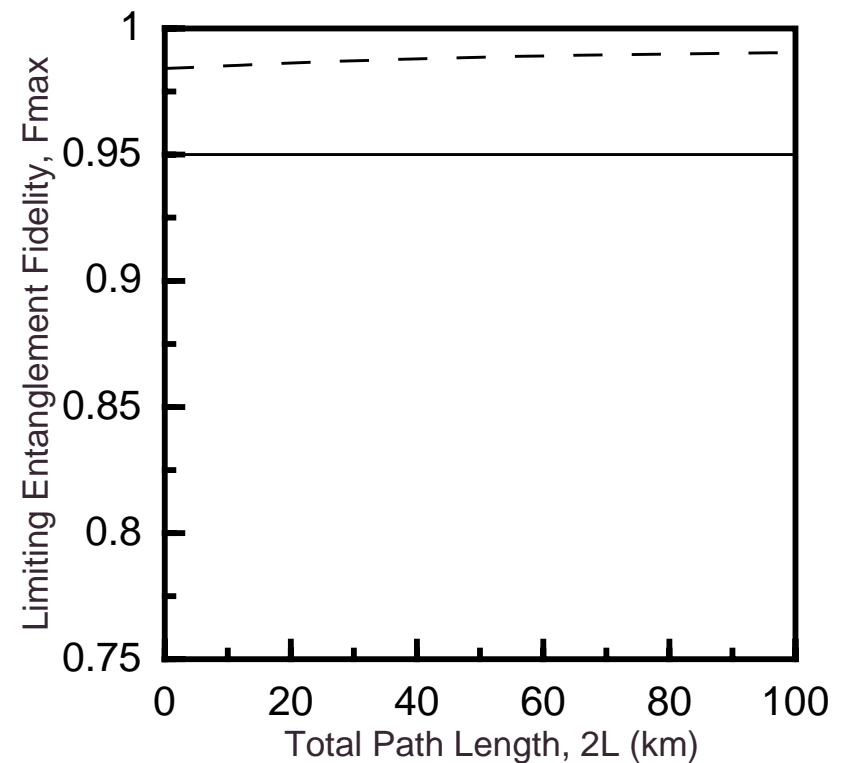
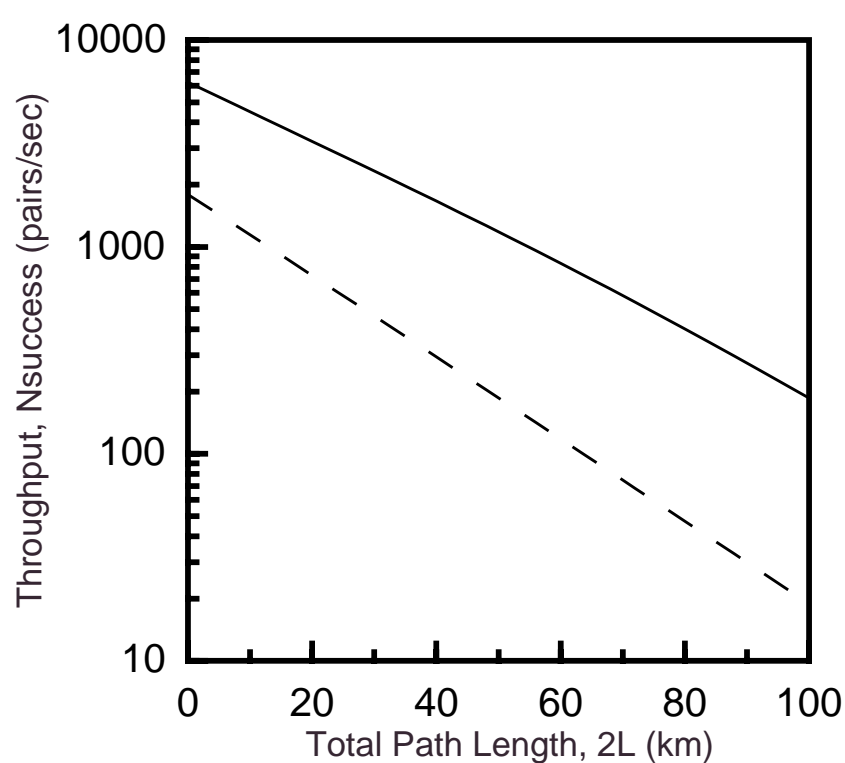

- SOLID CURVES: OPA Pumped to Maximize N_{success} with $F_{\text{max}} = 0.95$
- DASHED CURVES: OPA Pumped at 1% of Threshold

QUBIT TELEPORTATION USING SINGLET STATES

Figures of Merit

- CYCLING RATE $R = 500$ kHz
- FIBER LOSS 0.2 dB/km; FIXED LOSSES 5 dB PER P -TO- M LINK

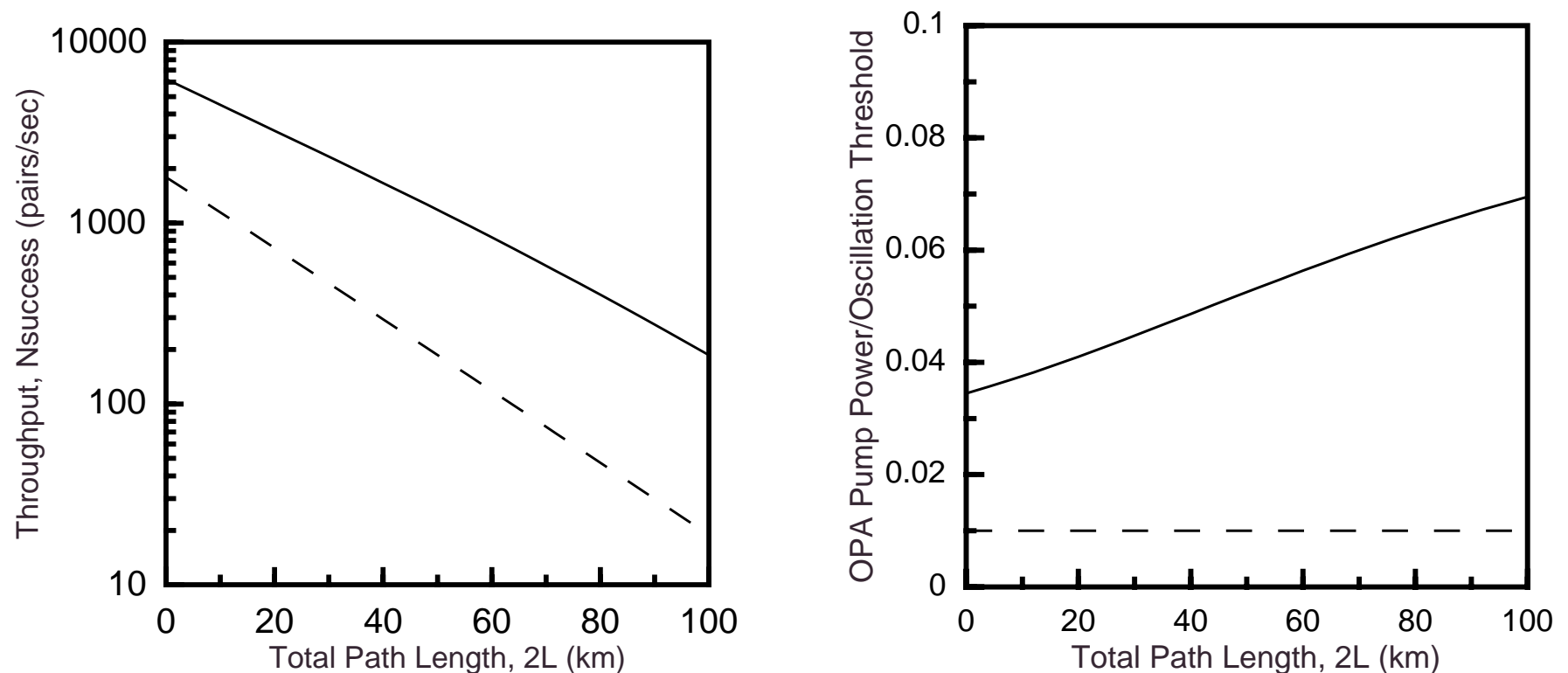

- SOLID CURVES: OPA Pumped to Maximize N_{success} with $F_{\text{max}} = 0.95$
- DASHED CURVES: OPA Pumped at 1% of Threshold

QUBIT TELEPORTATION USING SINGLET STATES

Essential Components of Quantum Communication System

(a) ULTRABRIGHT NARROWBAND ENTANGLEMENT SOURCE

(b) SIMPLIFIED ATOMIC-LEVEL SCHEMATIC OF QUANTUM MEMORY

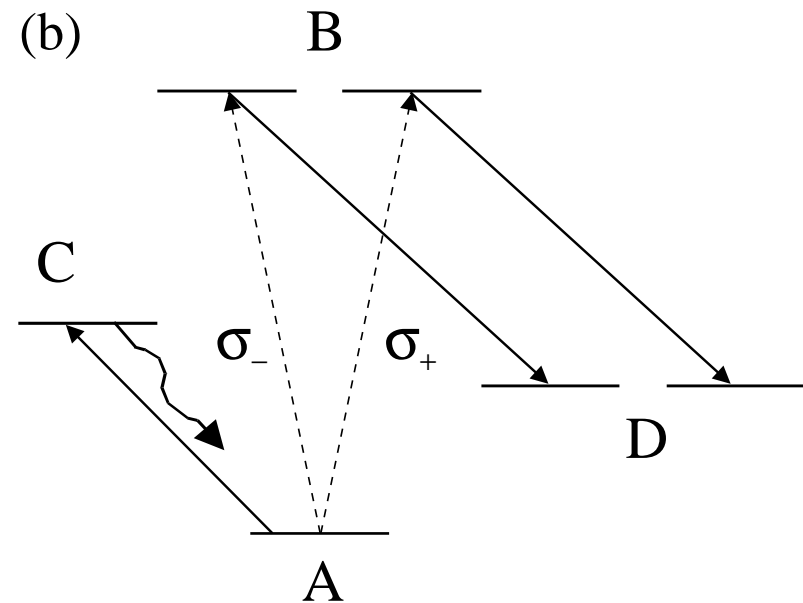
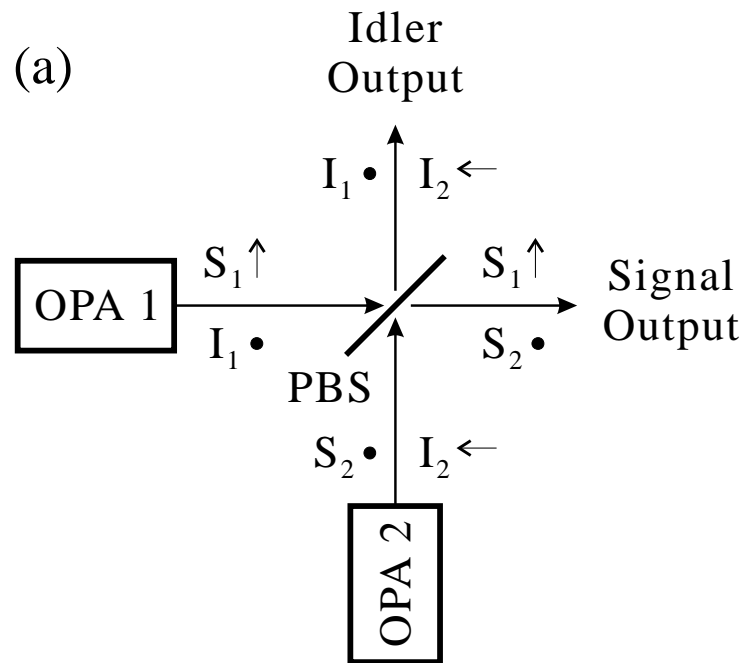

GENERATING ENTANGLED PHOTONS

PHYSICS OF $\chi^{(2)}$ INTERACTIONS

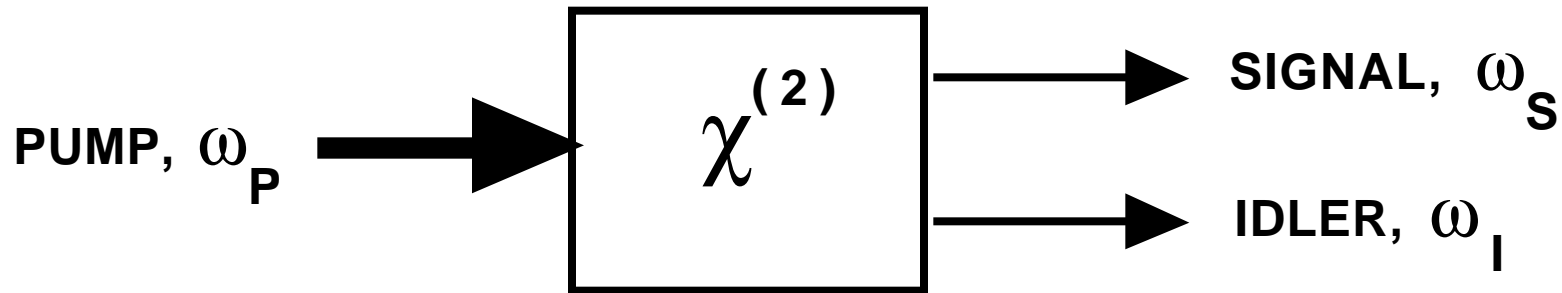

- STRONG PUMP AT FREQUENCY ω_P and WAVE NUMBER \vec{k}_P
- SIGNAL AND IDLER BEAMS AT ω_j, \vec{k}_j , FOR $j = S, I$
- ENERGY CONSERVATION: $\omega_S + \omega_I = \omega_P$
- MOMENTUM CONSERVATION: $\vec{k}_S + \vec{k}_I = \vec{k}_P$

OPTICAL PARAMETRIC AMPLIFIER (OPA)

SUB-THRESHOLD OPTICAL PARAMETRIC OSCILLATOR

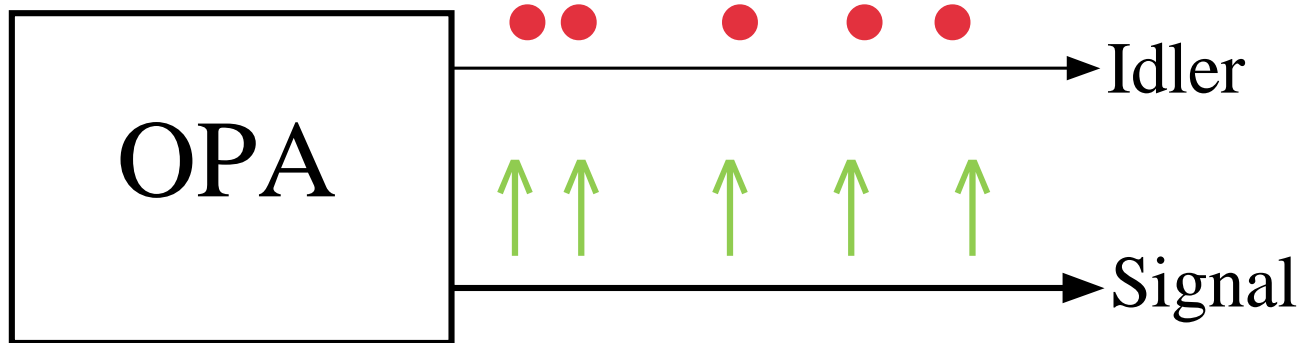

- SIGNAL AND IDLER PHOTONS PRODUCED IN PAIRS
- TYPE-II PHASE MATCHING \longrightarrow ORTHOGONAL POLARIZATIONS

DUAL-OPA POLARIZATION ENTANGLEMENT

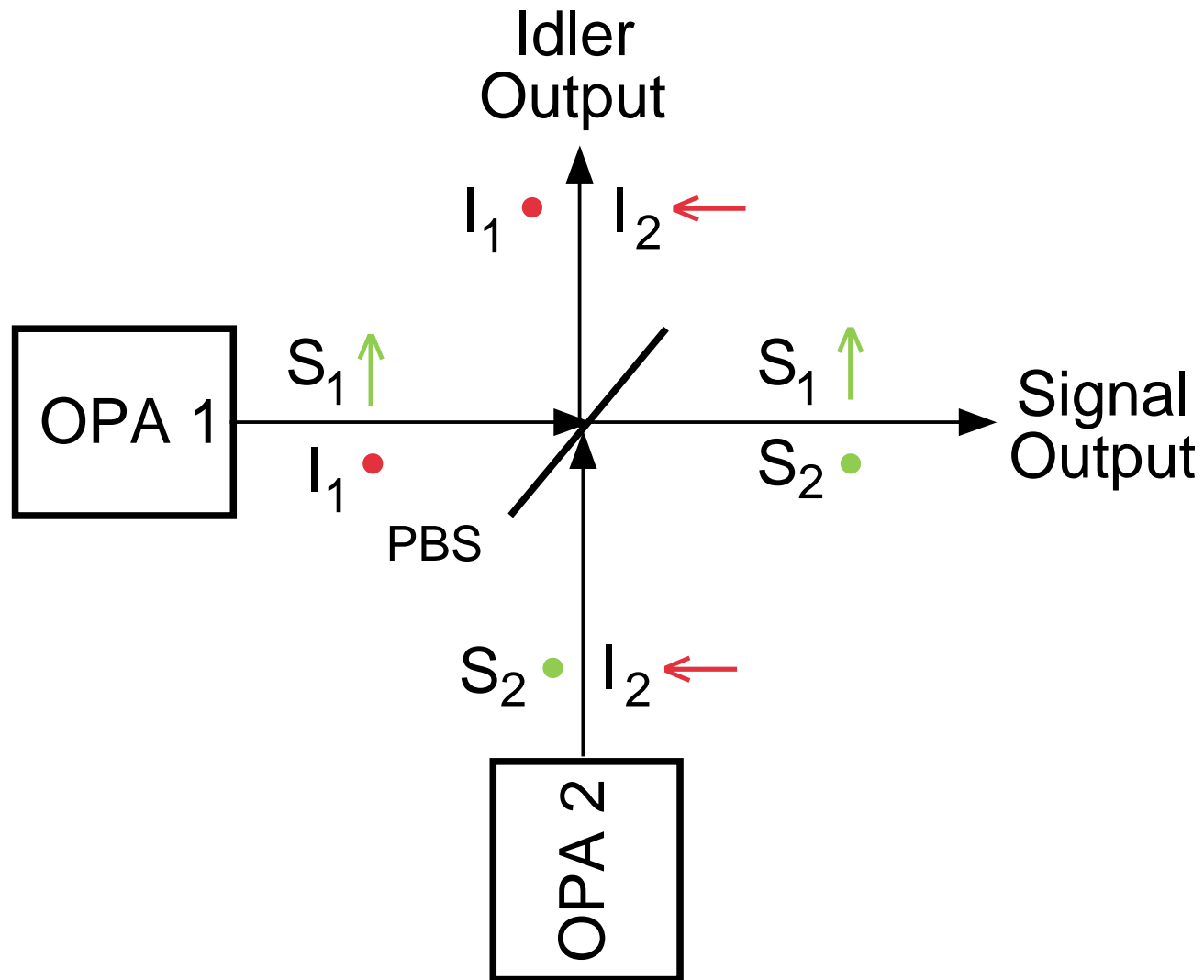

DUAL-OPA SOURCE OF POLARIZATION ENTANGLED PHOTON PAIRS*

Singlet-State Generation with Anti-Phased Pumps

- INTERNAL EQUATIONS OF MOTION FOR k th OPA

$$\left(\frac{d}{dt} + \Gamma\right)\hat{a}_{S_k}(t) = (-1)^k G\Gamma\hat{a}_{I_k}^\dagger(t) + \sqrt{2\Gamma}\hat{A}_{S_k}^{\text{IN}}(t)$$

$$\left(\frac{d}{dt} + \Gamma\right)\hat{a}_{I_k}(t) = (-1)^k G\Gamma\hat{a}_{S_k}^\dagger(t) + \sqrt{2\Gamma}\hat{A}_{I_k}^{\text{IN}}(t)$$

- SIGNAL AND IDLER OUTPUTS

$$\hat{A}_{S_k}(t) = \sqrt{2\Gamma}\hat{a}_{S_k}(t) - \hat{A}_{S_k}^{\text{IN}}(t)$$

$$\hat{A}_{I_k}(t) = \sqrt{2\Gamma}\hat{a}_{I_k}(t) - \hat{A}_{I_k}^{\text{IN}}(t)$$

- VECTOR SIGNAL AND IDLER BEAMS

$$\hat{\vec{E}}_S(t) = (\hat{A}_{S_1}(t)\vec{i}_x + \hat{A}_{S_2}(t)\vec{i}_y)e^{-i\omega_S t}$$

$$\hat{\vec{E}}_I(t) = (\hat{A}_{I_2}(t)\vec{i}_x + \hat{A}_{I_1}(t)\vec{i}_y)e^{-i\omega_I t}$$

*J.H. Shapiro and N.C. Wong, "An ultrabright narrowband source of polarization-entangled photon pairs," J. Opt. B, vol. 2, pp. L1-L4 (2000).

DUAL-OPA SOURCE OF POLARIZATION ENTANGLED PHOTON PAIRS

Photon Counting Statistics

- \vec{i} -POLARIZED SIGNAL-FIELD OPERATOR: $\vec{i} \equiv i_x \hat{x} + i_y \hat{y}$, $\vec{i}^* \cdot \vec{i} = 1$

$$\hat{A}_S(t) \equiv \vec{i}^* \cdot \hat{\vec{E}}_S(t) e^{i\omega_S t}$$

- \vec{i}' -POLARIZED IDLER-FIELD OPERATOR: $\vec{i}' \equiv i_y^* \hat{x} - i_x^* \hat{y}$

$$\hat{A}_I(t) \equiv \vec{i}'^* \cdot \hat{\vec{E}}_I(t) e^{i\omega_I t}$$

- T -SEC PHOTON-COUNTING MEASUREMENTS

$$\hat{N}_S \equiv \int_0^T dt \hat{A}_S^\dagger(t) \hat{A}_S(t) \quad \text{and} \quad \hat{N}_I \equiv \int_0^T dt \hat{A}_I^\dagger(t) \hat{A}_I(t)$$

- PHOTON-COUNT DIFFERENCE VARIANCE

$$\frac{\langle \Delta \hat{N}^2 \rangle}{\langle \hat{N}_S \rangle + \langle \hat{N}_I \rangle} = \frac{1 - \exp(-2\Gamma T)}{2\Gamma T} \longrightarrow \begin{cases} 1, & \text{for } \Gamma T \ll 1, \\ 0, & \text{for } \Gamma T \gg 1 \end{cases}$$

DUAL-OPA SINGLET-STATE GENERATION

- ENTANGLED SIGNAL/IDLER FREQUENCIES: $\omega_S + \Delta\omega, \omega_I - \Delta\omega$
- ENTANGLED BOSE-EINSTEIN STATE: $P_n \equiv \bar{N}^n / (\bar{N} + 1)^{n+1}$

$$|\psi\rangle_{SI} = \sum_{n=0}^{\infty} \sqrt{P_n} |n\rangle_{S\uparrow} |n\rangle_{I\bullet} \bullet \sum_{n=0}^{\infty} (-1)^n \sqrt{P_n} |n\rangle_{S\bullet} |n\rangle_{I\uparrow}$$

\bar{N} = Average Photon-Number per Mode

- SINGLET-STATE APPROXIMATION IN $\bar{N} \ll 1$ LIMIT

$$|\psi\rangle_{SI} \longrightarrow \frac{1}{\bar{N} + 1} |0\rangle_{S\uparrow} |0\rangle_{I\bullet} |0\rangle_{S\bullet} |0\rangle_{I\uparrow} + \sqrt{\frac{\bar{N}}{(\bar{N} + 1)^3}} (|1\rangle_{S\uparrow} |1\rangle_{I\bullet} |0\rangle_{S\bullet} |0\rangle_{I\uparrow} - |0\rangle_{S\uparrow} |0\rangle_{I\bullet} |1\rangle_{S\bullet} |1\rangle_{I\uparrow})$$

DUAL-OPA SOURCE OF POLARIZATION ENTANGLED PHOTON PAIRS

Quasi-Phase-Matched Ring Cavity Configuration

- PERIODICALLY-POLED KTP OPTICAL PARAMETRIC AMPLIFIERS
- $9\ \mu\text{m}$ -PERIOD FIRST-ORDER QPM; 795 nm OUTPUT WAVELENGTH

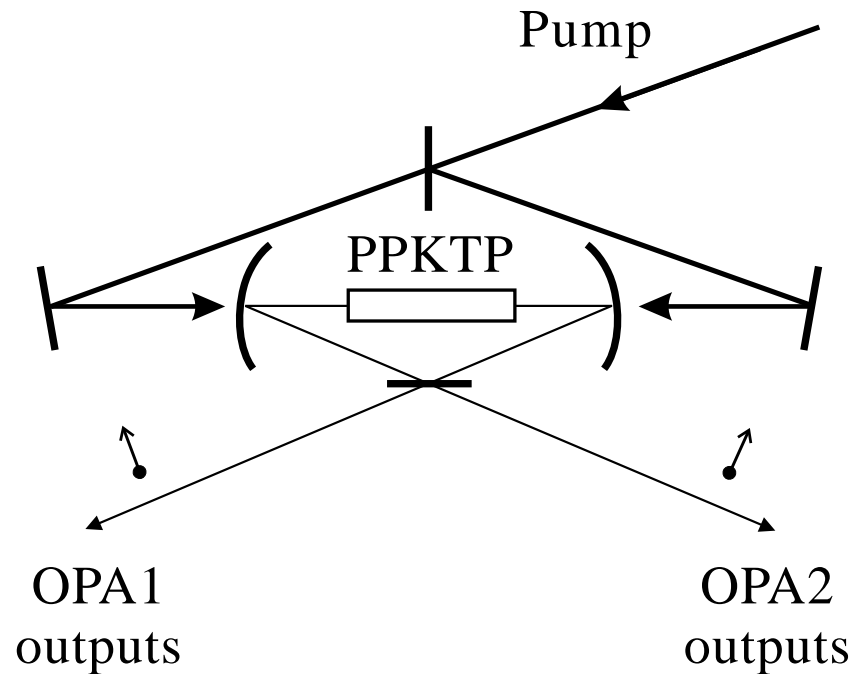

- 1%-THRESHOLD OPERATION; 30 MHz BANDWIDTH
- 20 mW PUMP POWER FOR 10-mm-LONG PPKTP CRYSTAL

QUBIT TRANSMISSION USING STANDARD FIBER*

Quantum-State Frequency Translation: 1608 nm \longrightarrow 795 nm

- TRAVELING-WAVE SUM-FREQUENCY GENERATOR

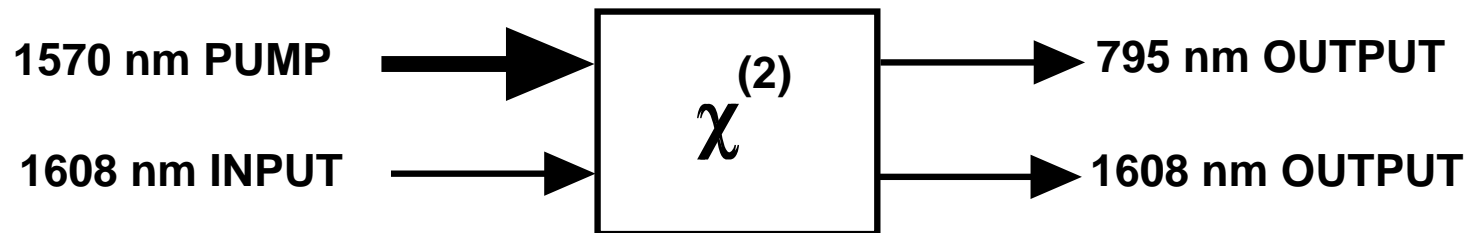

- INPUT-OUTPUT RELATION

$$\hat{A}_{795}^{\text{OUT}}(t) = \sin(\kappa\sqrt{P_{1570}})\hat{A}_{1608}^{\text{IN}}(t) + \cos(\kappa\sqrt{P_{1570}})\hat{A}_{795}^{\text{IN}}(t)$$

- PERIODICALLY-POLED LITHIUM NIOBATE UPCONVERTER
 - 5-cm-Long Crystal
 - 1 W Erbium-Doped Fiber-Amplifier Pump
 - 80% Estimated Conversion Efficiency

*P. Kumar, "Quantum frequency conversion," Opt. Lett., vol. 15, pp. 1476–1478 (1990); J.M. Huang and P. Kumar, "Observation of quantum frequency conversion," Phys. Rev. Lett., vol. 68, pp. 2153–2156 (1992).

QUBIT TRANSMISSION USING STANDARD FIBER

Time-Division Multiplexing to Compensate for Birefringence*

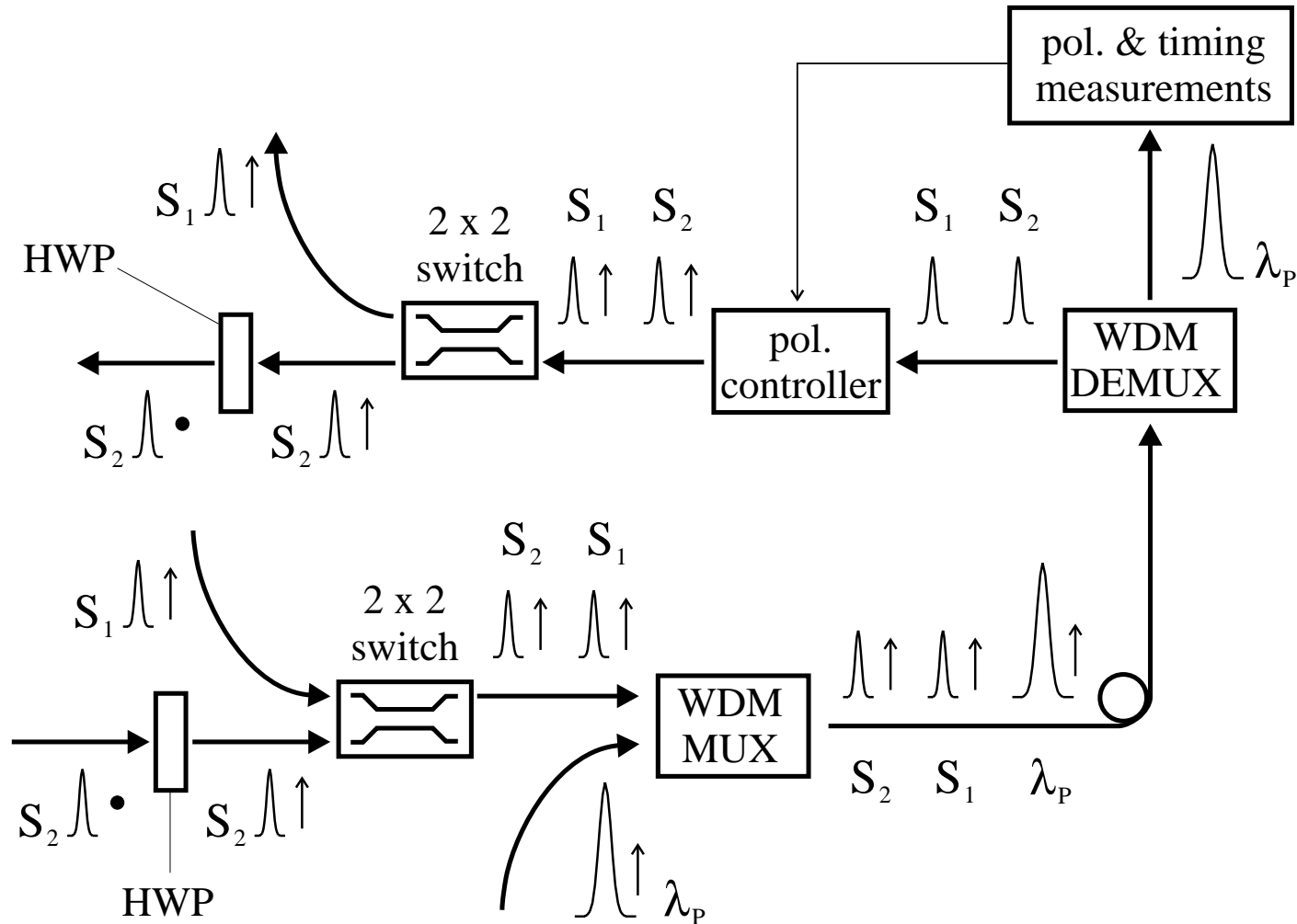

*K. Bergman, C.R. Doerr, H.A. Haus, and M. Shirasaki, "Sub-shot-noise measurement with fiber-squeezed optical pulses," Opt. Lett., vol. 18, pp. 643–645 (1993).

QUBIT TELEPORTATION USING SINGLET STATES

Essential Components of Quantum Communication System

(a) ULTRABRIGHT NARROWBAND ENTANGLEMENT SOURCE

(b) SIMPLIFIED ATOMIC-LEVEL SCHEMATIC OF QUANTUM MEMORY

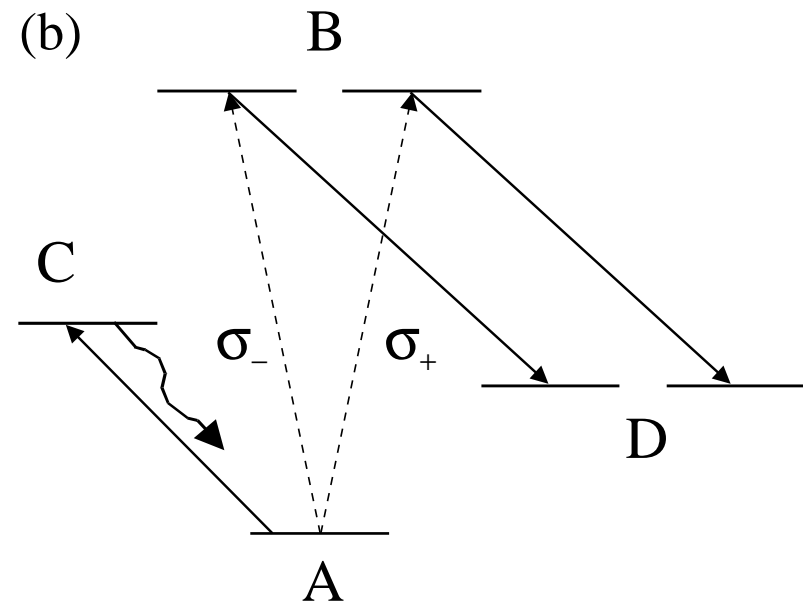
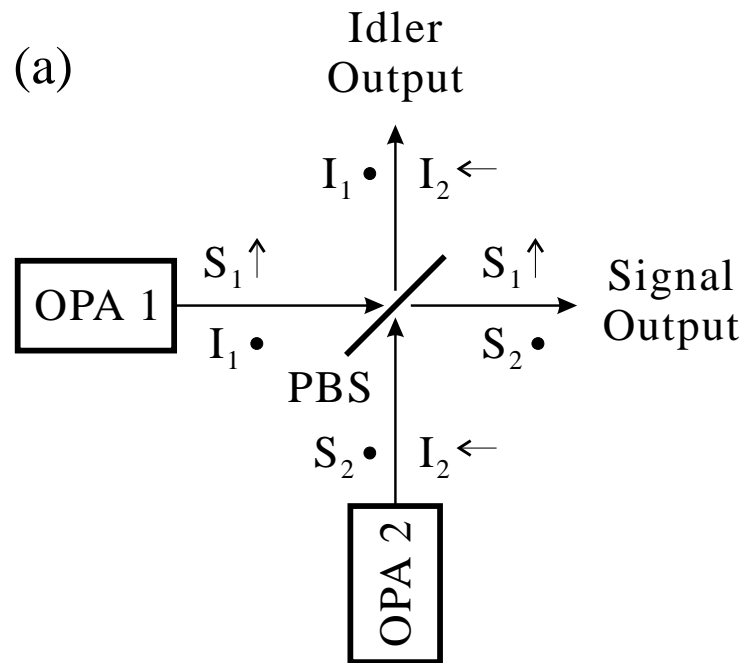

QUANTUM MEMORY IN TRAPPED ^{87}Rb ATOMS*

(a) HIGH-FINESSE OPTICAL CAVITY OF LASER-TRAPPED Rb

(b) DOUBLE CAVITY FOR ATOMIC-STATE TELEPORTATION

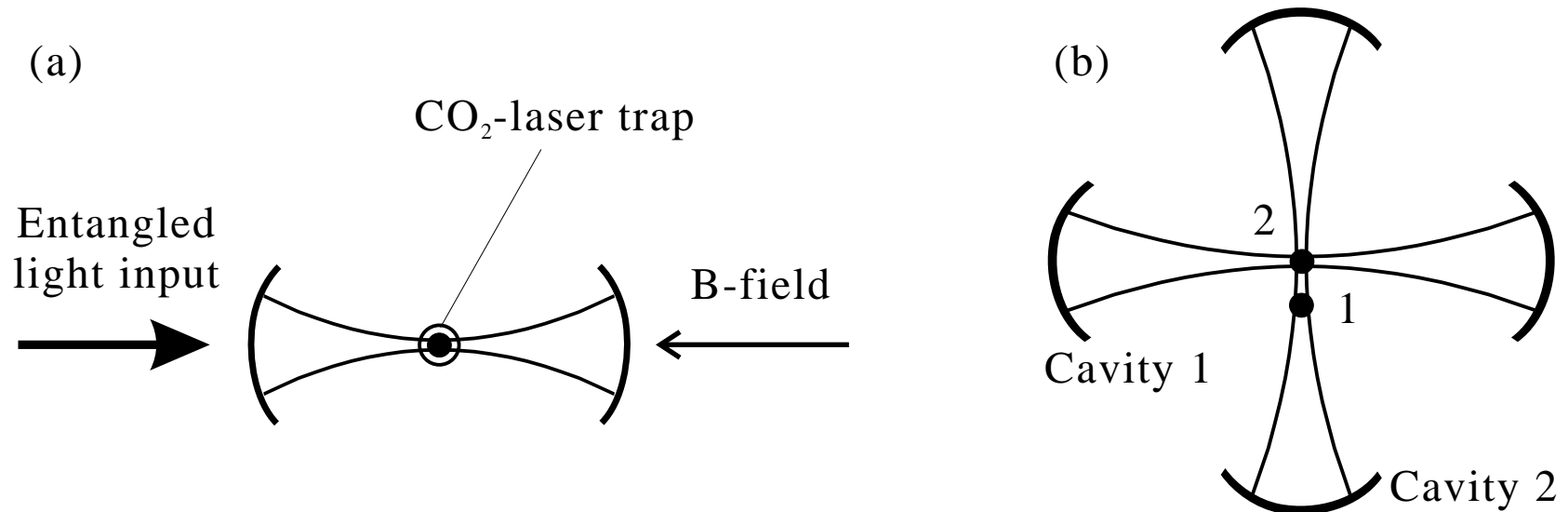

*S. Lloyd, M.S. Shahriar, and P.R. Hemmer, "Teleportation and the quantum Internet," submitted to Phys. Rev. A. (<http://qop.mit.edu/papers/qunetfinal.pdf>)

QUANTUM MEMORY IN TRAPPED ^{87}Rb ATOMS

Atomic Levels for Qubit Storage and Load Verification

(a) ENERGY LEVELS FOR STORAGE

- *A* Level $\longleftrightarrow F = 1, m_F = 0$ Ground State
- *B* Levels $\longleftrightarrow F = 1, m_F = \pm 1$ Excited State
- *D* Levels $\longleftrightarrow F = 2, m_F = \pm 1$ Ground States

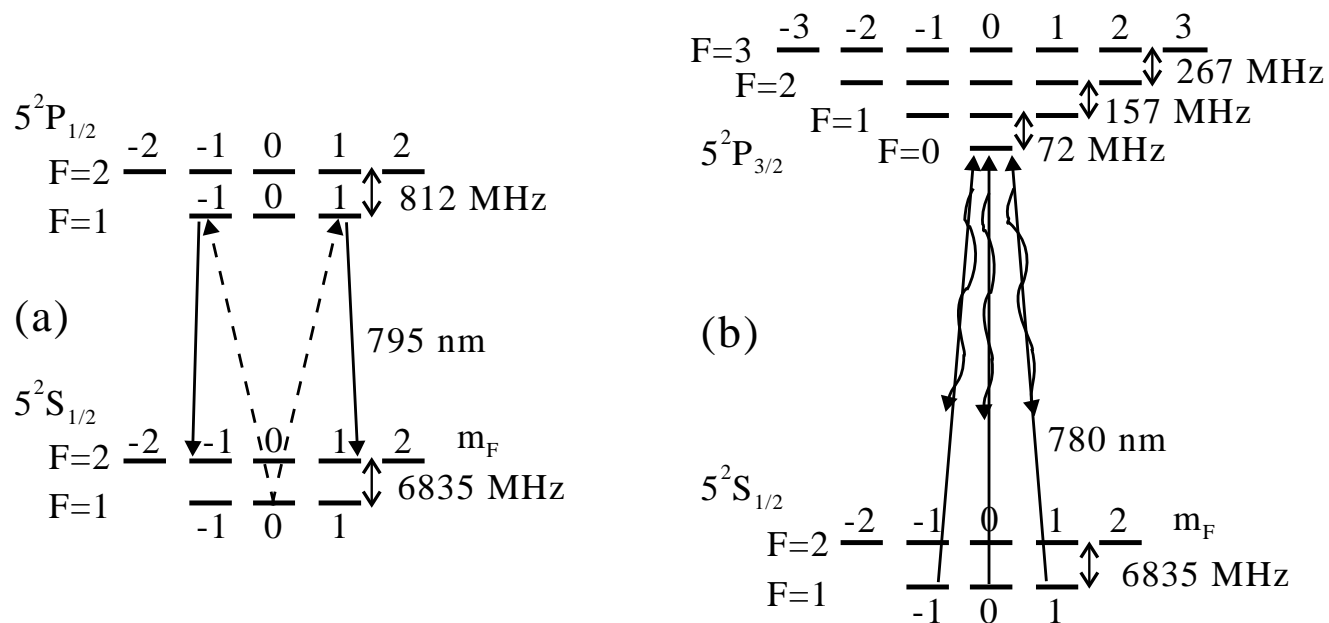

(b) NONDESTRUCTIVE LOAD VERIFICATION: *A*-to-*C* CYCLING

ATOMIC-STATE TELEPORTATION

SIMPLIFIED DESCRIPTION

- GROUND STATE A , CYCLING STATE C , FOUR LOGIC STATES

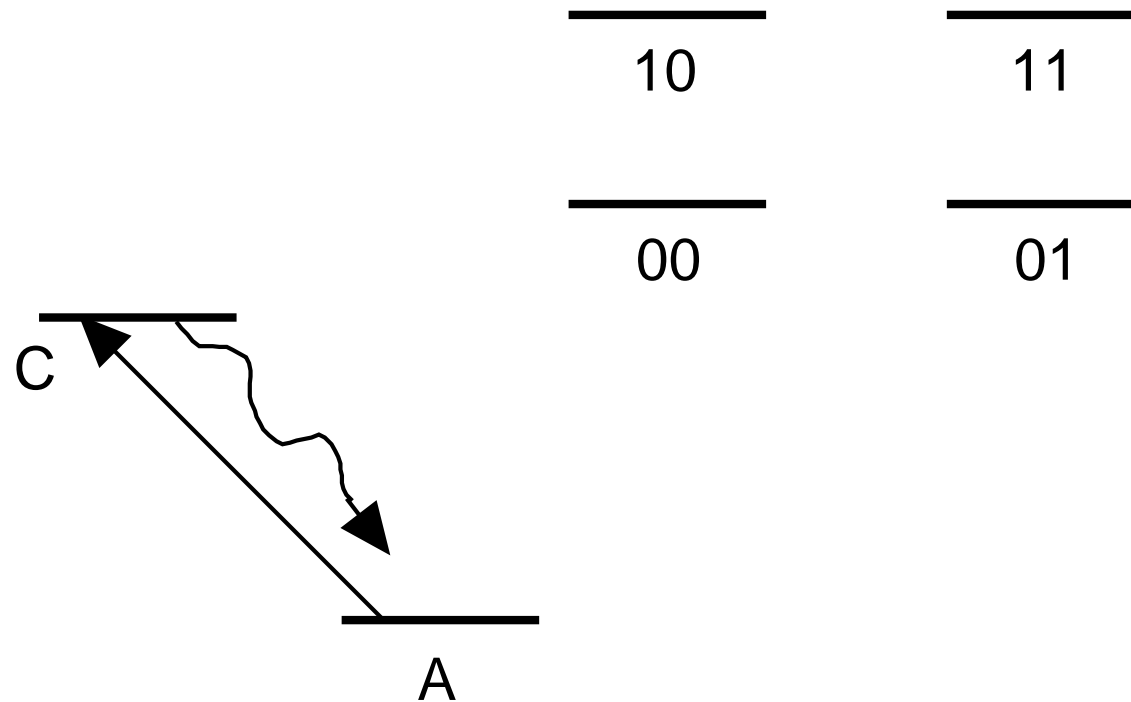

- QUBIT LOGIC MAPS BELL STATES TO LOGIC STATES
- BELL MEASUREMENTS VIA FLUORESCENCE DETECTION

ATOMIC-STATE TELEPORTATION

Preparation for Bell-State Measurements*

- LEFT: ENERGY-LEVEL DIAGRAM FOR ATOM 1

- RIGHT: ENERGY-LEVEL DIAGRAM FOR ATOM 2

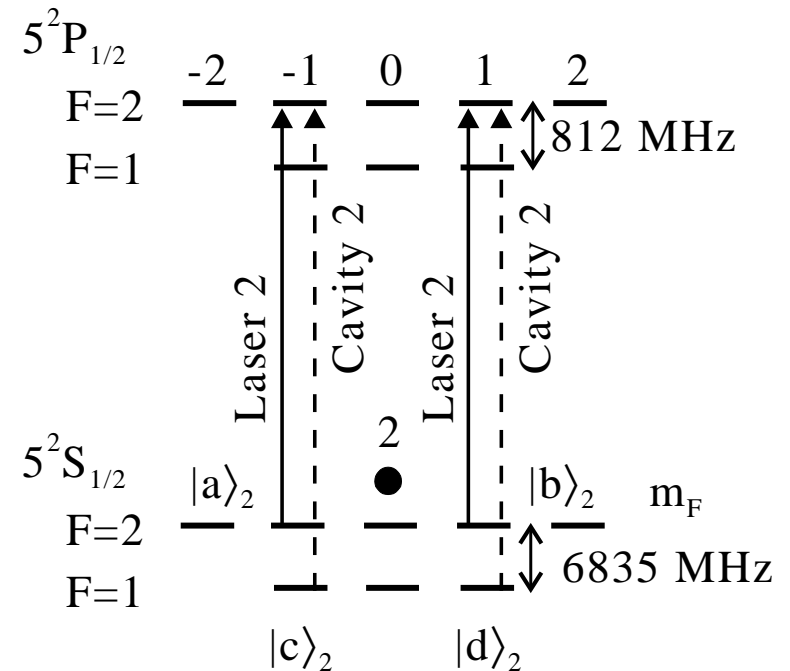
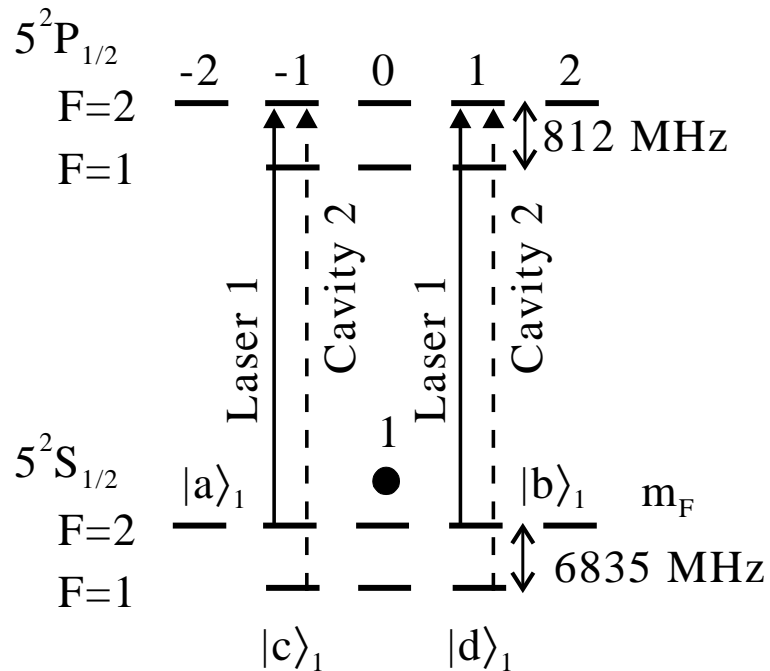

*T. Pellizzari, S.A. Gardiner, J.I. Cirac, and P. Zoller, "Decoherence, continuous observation, and quantum computing," Phys. Rev. Lett., vol. 75, pp. 3788–3791 (1995).

ATOMIC-STATE TELEPORTATION*

Performing the Bell-State Measurements

(a) OPTICAL OFF-RESONANT RAMAN TRANSITION

- Bell States Mapped to Bare Atomic States

(b) SEQUENTIAL BELL-STATE MEASUREMENTS

- Fluorescence Detection after Raman Excitations

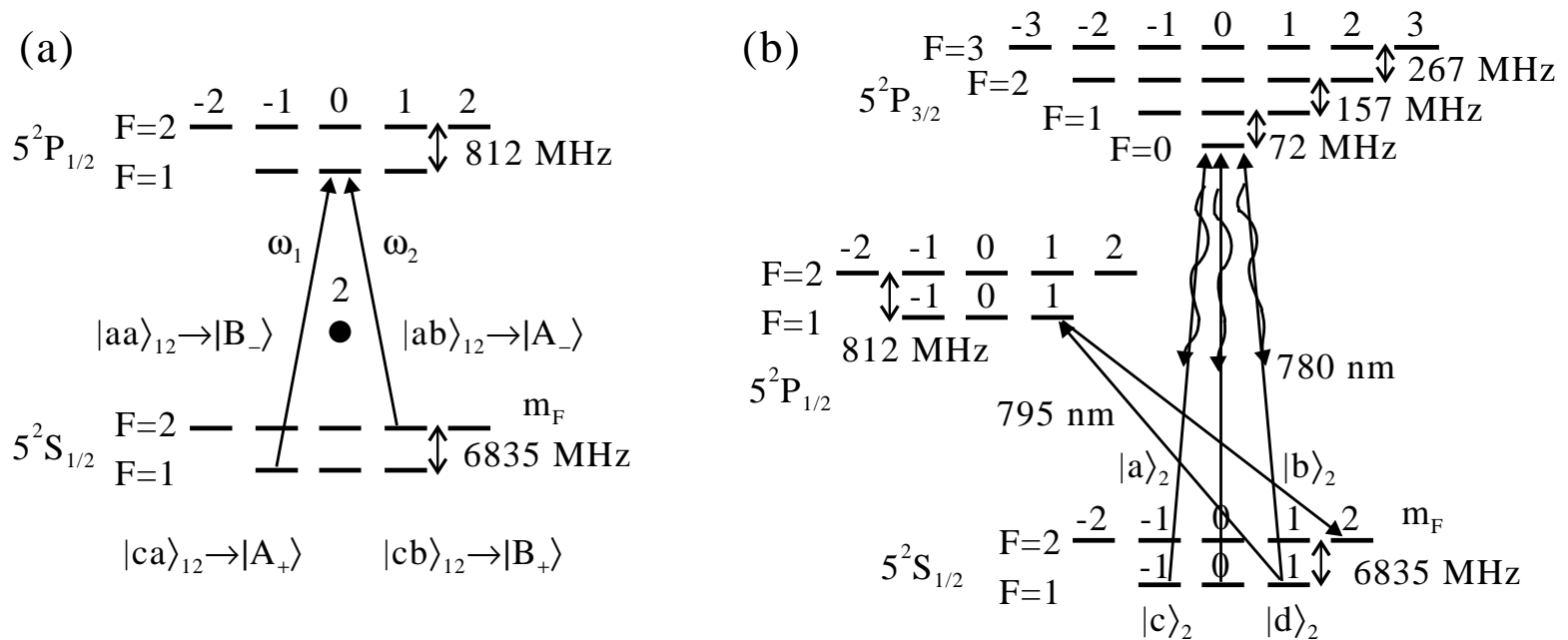

*S. Lloyd, M.S. Shahriar, and P.R. Hemmer, "Teleportation and the quantum Internet," submitted to Phys. Rev. Lett. (<http://qop.mit.edu/papers/qunetfinal.pdf>)

ANALOG QUANTUM INFORMATION

- CLASSICAL EM-FIELD SUPPORTS NOISELESS OSCILLATION
 - Phasor representation of single mode: $a e^{-i\omega t}$
 - Quadrature representation of state: $a = a_1 + i a_2$
- QUANTUM EM-FIELD OBEYS UNCERTAINTY PRINCIPLE
 - Operator representation of single mode: $\hat{a} e^{-i\omega t}$
 - Quadrature-representation uncertainty principle

$$\langle \Delta \hat{a}_1^2 \rangle \langle \Delta \hat{a}_2^2 \rangle \geq 1/16, \text{ where } \hat{a} = \hat{a}_1 + i \hat{a}_2$$

- COHERENT STATE: $\langle \Delta \hat{a}_1^2 \rangle = \langle \Delta \hat{a}_2^2 \rangle = 1/4$
- OPA OUTPUT MODES ARE QUADRATURE ENTANGLED
 $\langle (\Delta \hat{a}_{S1} - \Delta \hat{a}_{I1})^2 \rangle = s/4$ and $\langle (\Delta \hat{a}_{S2} + \Delta \hat{a}_{I2})^2 \rangle = s/4$, where $s < 1$

TELEPORTATION VIA FIELD QUADRATURES*

● THE TRANSMITTER STATION

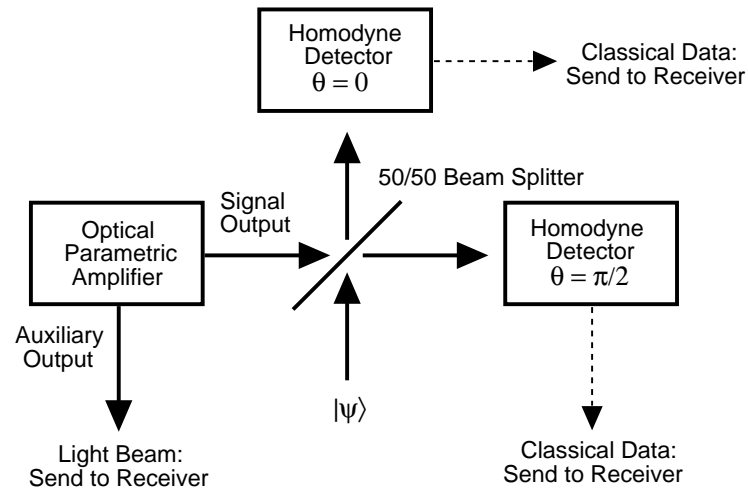

● THE RECEIVER STATION

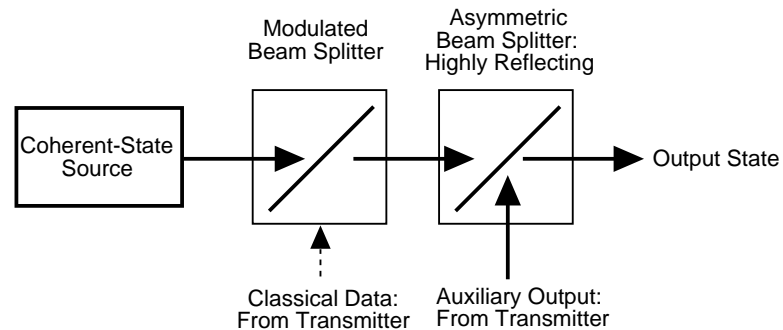

*S.L. Braunstein and H.J. Kimble, *Phys. Rev. Lett.*, “Teleportation of continuous quantum variables,” vol. 80, pp. 869–872 (1998); A. Furusawa, J.L. Sørensen, S.L. Braunstein, C.A. Fuchs, H.J. Kimble, and E.S. Polzik, “Unconditional quantum teleportation,” *Science*, vol. 282, pp. 706–709 (1998).

TELEPORTATION USING FIELD QUADRATURES

Quantum Repeater Chain for Analog Communication

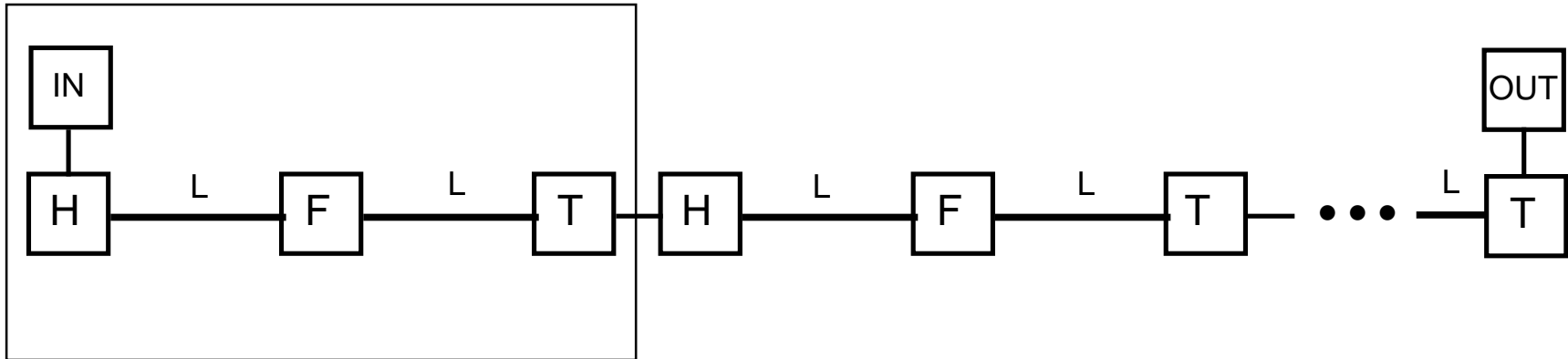

IN = Input State

F = Source of Entangled Field Quadratures

H = Dual-Homodyne Detector

T = Teleportation Completion via Modulated Mean-Field Injection

L = Optical Fiber Propagation Link

OUT = Output State

TELEPORTATION USING FIELD QUADRATURES

Single-Mode Analysis of One-Hop Teleportation

- INPUT-MODE ANNIHILATION OPERATOR: \hat{a}
- QUADRATURE-ENTANGLED SIGNAL AND IDLER MODES: \hat{a}_S, \hat{a}_I
- OUTPUT-MODE ANNIHILATION OPERATOR: \hat{b}
- INPUT-OUTPUT RELATION FOR SYMMETRIC LOSS

$$\hat{b} = \hat{a} + \sqrt{\epsilon}(\hat{a}_S^\dagger - \hat{a}_I) + \sqrt{(1-\eta)/\eta}\hat{a}_\eta + \sqrt{1-\epsilon}(\hat{a}_{S\epsilon}^\dagger - \hat{a}_{I\epsilon})$$

- HOMODYNE QUANTUM EFFICIENCY η
- PROPAGATION-PLUS-EXCESS LOSS ϵ
- VACUUM-STATE LOSS OPERATORS $\hat{a}_\eta, \hat{a}_{S\epsilon}, \hat{a}_{I\epsilon}$

TELEPORTATION USING FIELD QUADRATURES

Output-State Fidelity Analysis

- ***N*-STAGE SYMMETRIC-LOSS QUANTUM REPEATER CHAIN**

- **EIGENSPECTRUM FOR ARBITRARY INPUT STATE**

$$\hat{\rho}_a = \sum_n p_n |\psi_n\rangle\langle\psi_n|$$

- **INPUT-EIGENSTATE WIGNER CHARACTERISTIC FUNCTION**

$$\chi_W^{\psi_n}(\zeta^*, \zeta) \equiv \langle\psi_n| \exp(-\zeta^* \hat{a} + \zeta \hat{a}^\dagger) |\psi_n\rangle$$

- **OUTPUT-STATE FIDELITY**

$$F(\hat{\rho}_a) = \sum_n p_n \int \frac{d^2\zeta}{\pi} |\chi_W^{\psi_n}(\zeta^*, \zeta)|^2 \exp\{-N|\zeta|^2[(1-\epsilon) + (1-\eta)/\eta + \epsilon s]\}$$

s = Squeezing Parameter, $s = 1$ is Coherent-State Level

- **FIDELITY FOR COHERENT-STATE INPUT**

$$F_{\text{coh}} = \frac{1}{1 + N[(1 - \epsilon) + (1 - \eta)/\eta + \epsilon s]}$$

TELEPORTATION USING FIELD QUADRATURES

Output-State Fidelity for Coherent-State Input

- 99% QUANTUM EFFICIENCY DETECTORS ($\eta = 0.99$)
- $\epsilon < 1$ DUE ENTIRELY TO PROPAGATION LOSS: 0.2 dB/km

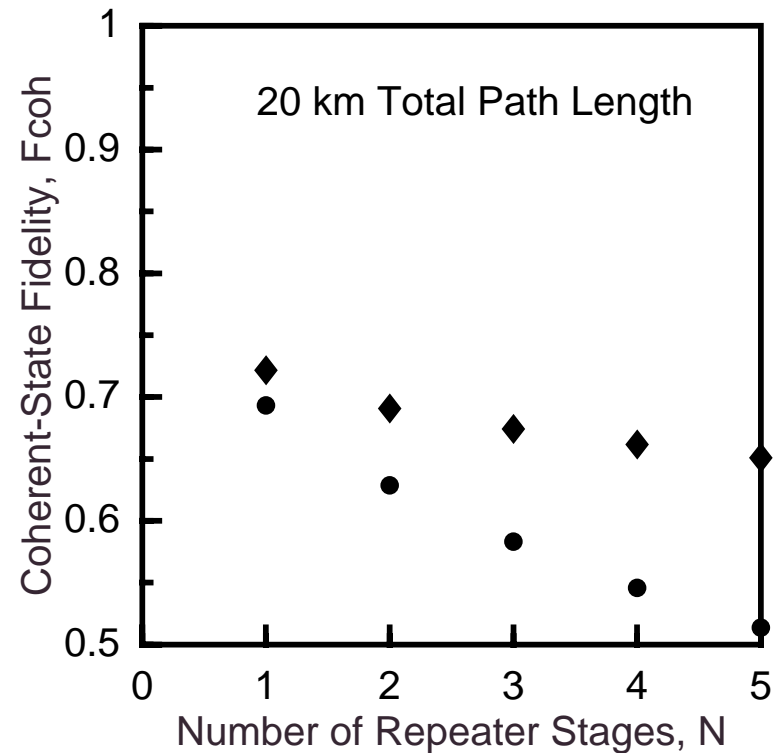
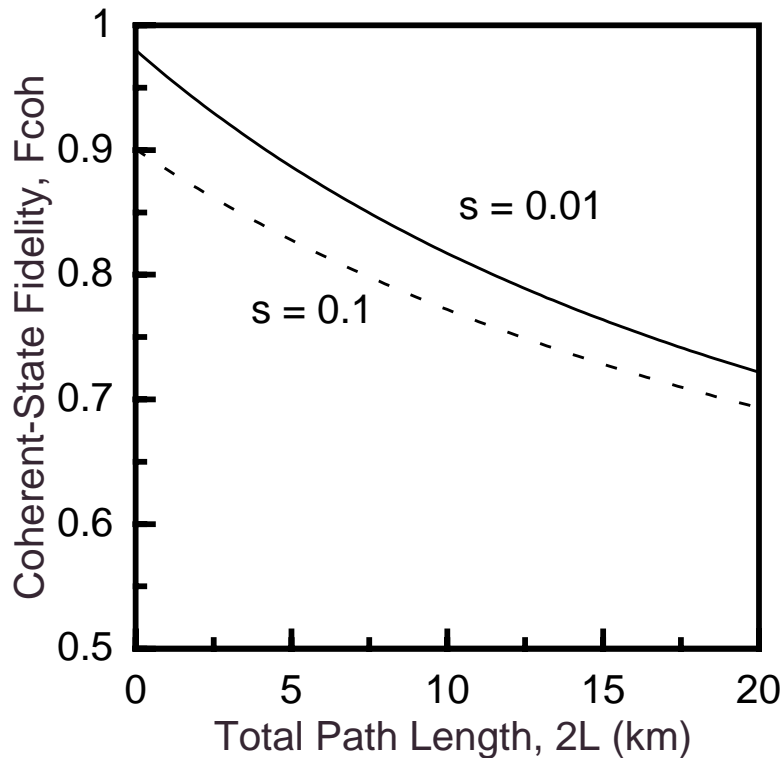

- 10 dB Squeezing (Dashed; Circles) vs. 20 dB Squeezing (Solid; Diamonds)

TELEPORTATION USING FIELD QUADRATURES

Soliton-Based Fiber-Optic Teleportation*

- SAGNAC-LOOP SOURCE: FIBER-TRANSMISSION COMPATIBILITY
- SOLITON SOURCE: SINGLE SPATIO-TEMPORAL MODE

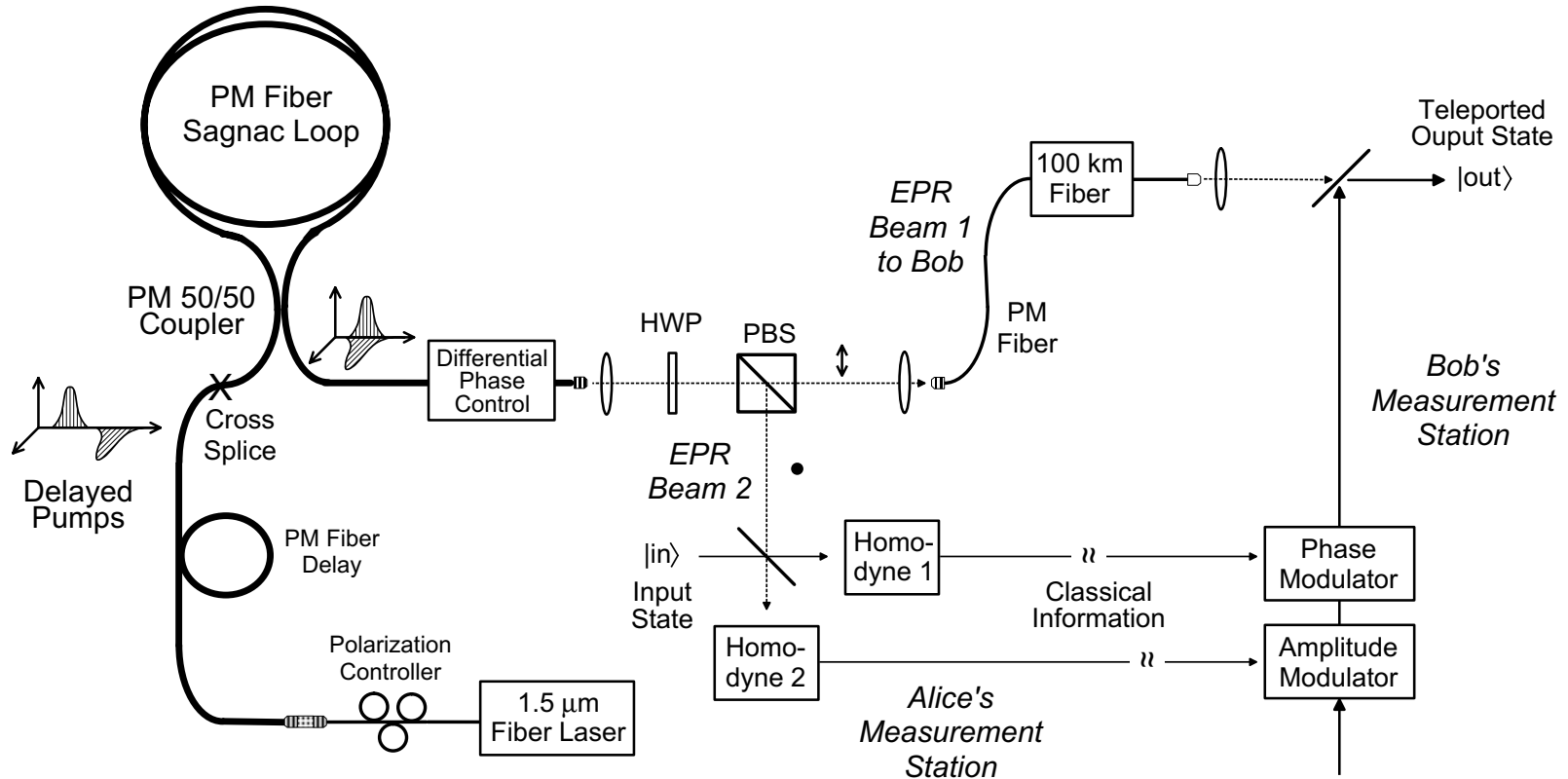

*D. Levandovsky, M. Vasilyev, and P. Kumar, "Amplitude squeezing of light by means of a phase-sensitive fiber parametric amplifier," *Opt. Lett.*, vol. 24, pp. 984–986 (1999).

QUANTUM INFORMATION TECHNOLOGY: Entanglement, Teleportation, and Memory

Massachusetts Institute of Technology and Northwestern University

- **TELEPORTATION USING SINGLET STATES**

- Dual-OPA Source of Polarization-Entangled Photon Pairs
- Long-Distance Transmission via Standard Optical Fiber
- Long-Duration Storage in Trapped-Atom Quantum Memory
- Bell-State Measurements in Trapped Atoms

- **QUADRATURE TELEPORTATION USING SOLITONS**

- Sagnac-Loop Source of Quadrature-Entangled Solitons
- Quadrature-Based Teleportation using Solitons
- Quantum Error Correction for Loss Mitigation

- **THEORETICAL STUDIES**

- Quantum Storage in a Fiber-Trapped Atom
- Quantum State Design
- Quantum Decoupling
- Photon-Number Amplification
- Secure Communication Protocols



QUANTUM INFORMATION TECHNOLOGY:

Entanglement, Teleportation, and Memory

Jeffrey H. Shapiro, MIT

jhs@mit.edu



Objectives -

Foundation for quantum communication technology via multidisciplinary, broad-based investigation

- **Develop singlet-state quantum communication, with quantum memory, that is capable of long-distance, high-fidelity transmission**
- **Develop all-fiber quantum communication system**
- **Develop new paradigms for quantum communication and quantum memory**

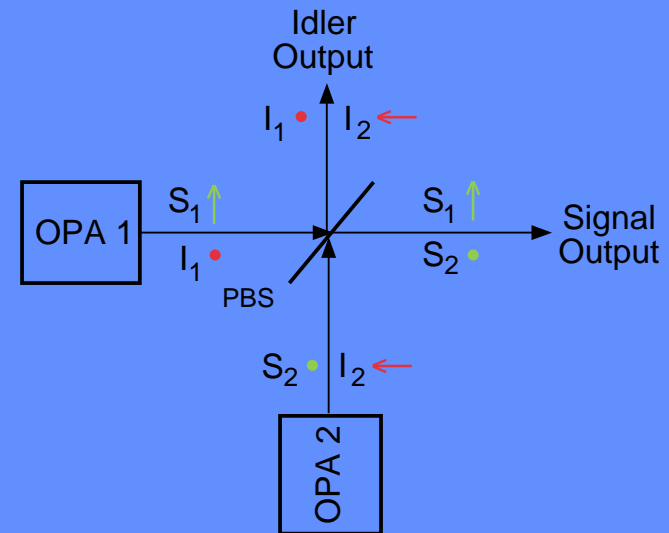

Program Elements -

- **Ultrabright narrowband source of polarization-entangled photon pairs**
- **Trapped-atom quantum memory in ^{87}Rb**
- **Entanglement transmission over standard telecommunication fiber**
- **Four Bell measurements in ^{87}Rb system**
- **Soliton quadrature-entanglement in fiber**
- **Single-mode quadrature-based teleportation**
- **Quantum communication protocols, loss models, state selection and error correction**

Schedule -

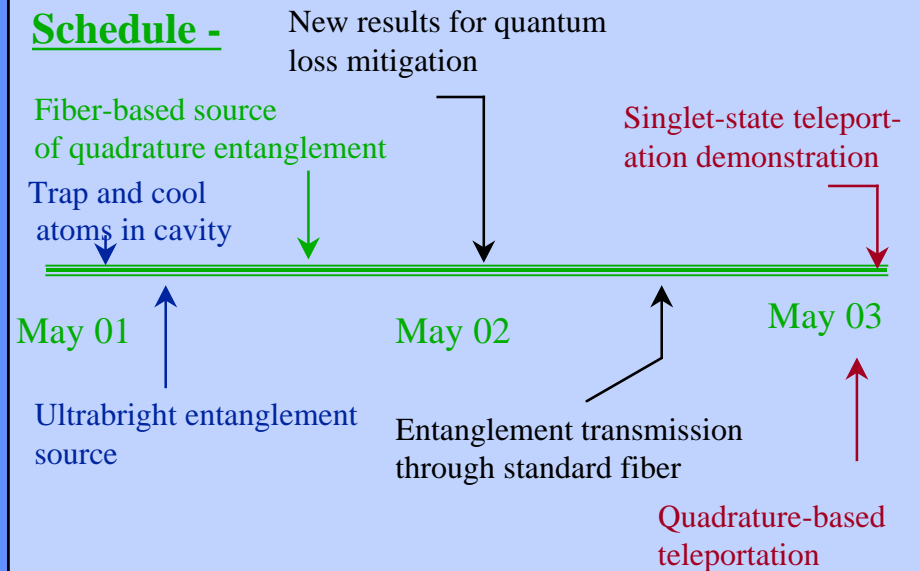



QUANTUM INFORMATION TECHNOLOGY: Entanglement, Teleportation, and Memory

Jeffrey H. Shapiro, MIT
jhs@mit.edu

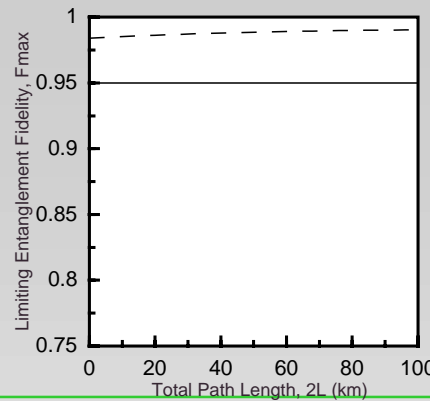
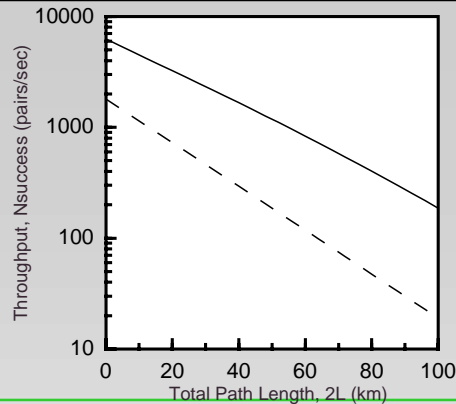

*Infrastructure for a Quantum Internet:
Long-Distance, High-Fidelity
Quantum Communication and Long-
Duration Quantum Memory*

FY01

- Demonstrate ultrabright narrowband source of polarization entanglement
- Set up fiber-based soliton squeezing system
- Trap and cool ^{87}Rb atoms in optical cavities
- Improved loss models and fidelity analyses for quantum communication

FY02

- Store polarization entanglement in trapped ^{87}Rb atoms
- Demonstrate fiber-based source of quadrature-entangled solitons
- Demonstrate Bell-state measurements in trapped ^{87}Rb atoms
- New results for quantum loss mitigation and error correction

FY03

- Demonstrate entanglement transmission through optical fiber
- Demonstrate singlet-state teleportation
- Demonstrate quadrature-based soliton teleportation
- New paradigms for quantum communication and memory