

# Chapter 1. Digital Signal Processing Research Program

## Academic and Research Staff

Professor Alan V. Oppenheim, Professor Arthur B. Baggeroer, Professor Anantha P. Chandrakasan, Professor Gregory W. Wornell, Giovanni Aliberti

## Visiting Scientists and Research Affiliates

Dr. Bernard Gold, Dr. Steven H. Isabelle, Dr. Frank Kschischang,<sup>1</sup> Dr. Hamid S. Nawab,<sup>2</sup> Dr. James C. Preisig, Dr. Charles Therrien,<sup>3</sup> Dr. Ehud Weinstein<sup>4</sup>

## Graduate Students

Rajeevan Amirtharajah, Richard J. Barron, Soosan Beheshti, Albert Chan, Brian Chen, Stark Draper, Trym H. Eggen, Christoforos N. Hadjicostis, Nicholas J. Laneman, Li Lee, Michael J. Lopez, Jeffrey T. Ludwig, James M. Ooi, Haralabos C. Papadopoulos, Matthew J. Secor, Alan J. Seefeldt, Charles K. Sestok, Wade P. Torres, Shawn M. Verbout, Kathleen E. Wage, Alex Che-Wei Wang

## Undergraduate Student

Maya R. Said

## Technical and Support Staff

Darla J. Chupp, Janice M. Zaganjori

## 1.1 Introduction

The field of digital signal processing grew out of the flexibility afforded by the use of digital computers in implementing signal processing algorithms and systems. It has since broadened into the use of a variety of both digital and analog technologies, spanning a broad range of applications, bandwidths, and realizations. The Digital Signal Processing group carries out research on algorithms for signal processing and their applications. Current application areas of interest include signal enhancement and active noise cancellation; speech, audio and underwater acoustic signal processing; advanced beamforming for radar and sonar systems; and signal processing and coding for wireless and broadband multiuser communication networks.

In some of our recent work, we have developed new methods for signal enhancement and noise cancellation with single or multisensor measurements. We have also been developing new methods for representing and analyzing fractal signals. This class of

signals arises in a wide variety of physical environments and also has potential in problems involving signal design. We are also exploring potential uses of nonlinear dynamics and chaos theory of signal design and analysis. Another emphasis is on structuring algorithms for approximate processing and successive refinement.

In other research, we are investigating applications of signal and array processing to ocean and structural acoustics and geophysics. These problems require the combination of digital signal processing tools with a knowledge of wave propagation to develop systems for short time spectral analysis, wavenumber spectrum estimation, source localization, and matched field processing. We emphasize the use of real-world data from laboratory and field experiments such as the Heard Island Experiment for Acoustic Monitoring of Global Warming and several Arctic acoustic experiments conducted on the polar ice cap.

<sup>1</sup> Professor, Department of Electrical and Computer Engineering, University of Toronto, Toronto, Canada.

<sup>2</sup> Associate Professor, Boston University, College of Engineering, Boston, Massachusetts.

<sup>3</sup> Professor, Department of Electrical and Computer Engineering, Naval Postgraduate School, Monterey, California.

<sup>4</sup> Department of Electrical Engineering, Systems Division, Faculty of Engineering, Tel-Aviv University, Israel; Adjunct Scientist, Department of Applied Ocean Physics and Engineering, Woods Hole Oceanographic Institution, Woods Hole, Massachusetts.

A major application focus of the group involves signal processing and coding for wireless multiuser systems and broadband communication networks. Specific interests include commercial and military mobile radio networks, wireless local area networks and personal communication systems, digital audio and television broadcast systems, and multimedia networks. Along with a number of other directions, we are currently exploring new code-division multiple-access (CDMA) strategies, new techniques for exploiting antenna arrays in wireless systems, and new methods for modeling and management of traffic in high-speed packet-switched networks.

Much of our work involves close collaboration with the Woods Hole Oceanographic Institution, MIT Lincoln Laboratory, and a number of high technology companies in the Boston area.

## 1.2 Dual-Channel Signal Processing

### Sponsors

Sanders, a Lockheed-Martin Corporation  
Contract BZ4962

U.S. Army Research Laboratory  
Contract DAAL01-96-2-0001

U.S. Navy - Office of Naval Research  
Grant N00014-93-1-0686

### Project Staff

Richard J. Barron, Professor Alan V. Oppenheim

In some sensor scenarios, it can be expected that sensor signals can be transmitted to a host over multiple channels with differing characteristics and that potentially the host can simultaneously transmit control signals to the sensors. For example, there might simultaneously be available from the sensor to the host a noisy analog full-band channel, and a low-bandwidth noise free channel. This scenario may occur when there is an existing analog communications infrastructure that is augmented by a low-bandwidth digital side channel. Another example that can be viewed in this context involves two sensors; one sensor observes a distorted full-bandwidth form of the source signal, while the other, a "spy" sensor, observes the source undistorted, but can only record or transmit a low-bandwidth representation of the signal. An open and interesting research question in this scenario is how to pre-process data at the sensor to condition it for transmission over the low-bandwidth channel for optimum processing of the dual-channel

information at the host. We can generalize the dual-channel problem by putting in place of the noisy analog channel any distortion-inducing channel through which the sensor signal is transmitted uncoded, examples of which are memoryless channels such as the additive white Gaussian noise channel, fading channels with memory, jamming channels, and unknown channels. For these and other channels, there are potentially elegant solutions for preprocessing at the sensor for transmission over the noise-free channel involving unique applications of parametric modeling, signal transforms, quantization, and control signals from the host.

## 1.3 Multipass Receivers for Spread-Signature CDMA Systems

### Sponsors

National Science Foundation  
Grant MIP 95-02885

U.S. Navy - Office of Naval Research  
Grant N00014-93-1-0686  
Grant N00014-96-1-0930

### Project Staff

Soosan Beheshti, Professor Gregory W. Wornell

Spread-signature code-division multiple-access (CDMA) systems were recently introduced as an attractive alternative to conventional CDMA systems for use in time-varying multipath environments. Using long signatures in an overlapped manner for successive symbols, spread-signature CDMA can achieve a substantial temporal diversity benefit. Furthermore, the broadband nature of the signatures allows an additional spectral diversity benefit to be simultaneously realized.

In this research, computationally efficient multipass demodulation and decoding algorithms are developed for use in receivers with these systems. These algorithms efficiently suppress both intersymbol and interuser (multiple-access) interference to achieve a substantial diversity benefit and good near-far resistance characteristics. Moreover, it is shown that relatively few iterations are required for convergence to typical target bit-error rates. Several other aspects of the performance of the algorithms are also explored.

## 1.4 Channel Equalization

### Sponsor

National Science Foundation  
Grant MIP 95-02885

### Project Staff

Albert Chan, Professor Gregory W. Wornell

The goal of channel equalization is to minimize the probability of error by compensating for channel distortion. One basic approach to channel equalization is to use the decision-feedback equalizer (DFE). The portion of the DFE that cancels postcursor intersymbol interference (ISI) is nonlinear; as a consequence of this, the postcursor equalizer portion does not enhance noise. By contrast, the portion of the DFE that cancels precursor ISI is linear, limiting its capabilities and leaving behind a significant amount of residual precursor ISI.

We are currently working on a simple yet effective equalizer that cancels both precursor and postcursor ISI in a nonlinear fashion, based on the multipass equalizer described in Beheshti.<sup>5</sup> This equalizer suppresses both intersymbol and interuser interference in spread-signature code-division multiple-access systems, but we are adapting that equalizer to the single-user, fixed-channel scenario. Our modified equalizer appears to perform better than the DFE in simulations. In order to explain the improved performance, we are now seeking an elegant way to relate the structure of the DFE to the structure of the modified multipass equalizer.

## 1.5 Steganographic Communication

### Sponsors

National Defense Science and Engineering  
Fellowship  
U.S. Air Force - Office of Scientific Research  
Grant F49620-96-1-0072  
U.S. Navy - Office of Naval Research  
Grant N00014-93-1-0686  
Grant N00014-96-1-0930

### Project Staff

Brian Chen, Professor Gregory W. Wornell

Steganography, or hidden communication, involves the embedding of an information-bearing signal within a host signal, such that the embedded signal cannot be easily detected or destroyed by some adversary. Applications include digital watermarking for copyright protection, captioning, and covert communication, and typical host signals are audio signals, video signals, and images. In our work we are developing a general framework for designing such systems, evaluating their performance, and understanding the fundamental limits of steganographic communication.

## 1.6 Data Transmission and Storage under Dynamic Bandwidth Constraints

### Sponsor

U.S. Navy - Office of Naval Research  
Grant N00014-93-1-0686

### Project Staff

Stark Draper, Professor Gregory W. Wornell

The general problem of data transmission and storage can be broken into two subproblems: (1) feature extraction from the raw data, and (2) optimal methods to transmit or store these features. Our research interests lie more heavily with the latter; specifically, in the case where a certain variety of independent features needs be communicated but where available bandwidth varies in time. Either the physical bandwidth of our channel may vary, or we may receive information about new features that must be transmitted in parallel over a constant-bandwidth channel. Both cases can be modeled as bandwidth variations. We would like to design a robust communication scheme whose performance degrades (or improves) elegantly with such variations.

<sup>5</sup> S. Beheshti and G. Wornell, "Iterative Interference Cancellation and Decoding for Spread-Signature CDMA Systems," *Proceedings of the International Vehicular Technology Conference*, Phoenix, Arizona, May 4-7, 1997.

## 1.7 Underwater Acoustic Communication over Doppler Spread Channels

### Sponsor

U.S. Navy - Office of Naval Research  
Grant N00014-95-1-0362  
Grant N00014-93-1-0686

### Project Staff

Trym H. Eggen, Professor Arthur B. Baggeroer

This work is concerned with coherent communication by means of acoustic signals over underwater communication channels. The estimated scattering functions of real data ranging from the Arctic environment to tropical waters show that underwater communication channels cannot be captured by a single, simple channel model. This work considers mainly a subset of underwater communication channels where the Doppler spread is more severe than the delay spread.

An appropriate representation of the linear time-variant channel is introduced and the wide sense stationary uncorrelated scattering (WSSUS) channel assumption enables characterization in terms of scattering functions. The concept of Doppler lines, which are frequency domain filters, is used in the derivation of a receiver for Doppler spread channels.

The channel is simulated by means of a ray representation for the acoustic field and a time-variant FIR filter. The impact of physical ocean processes on the Doppler spread is demonstrated, and from this modeling explanations for the Doppler spread observed in real data are obtained.

A decision feedback equalizer (DFE) adapted with recursive least squares (RLS) is analyzed, and its limit with respect to pure Doppler spread is found. By using the DFE with a phase locked loop (PLL), sub-optimal system behavior is found, and this is verified on real data. In the case of a simple Doppler shift, the cross-ambiguity function is used to estimate the shift, and the received signal is phase rotated to compensate for this before it enters the receiver.

A modified RLS called the time updated RLS (TU-RLS) is presented, and it is used in a new receiver. This receiver is initialized by means of the cross-ambiguity function and the performance is characterized by probability of decoding error versus delay spread, Doppler spread and SNR. The receiver uses Doppler lines to compensate both discrete and continuous Doppler spread. The receiver stability depends on the conditioning of the block diagonal correlation matrix propagated by the TU-RLS. The receiver is used to decode both real and simulated data, and some of these data are severely Doppler spread.

## 1.8 Algebraic and Probabilistic Structure in Fault-Tolerant Computation

### Sponsors

Sanders, a Lockheed-Martin Corporation  
Contract BZ4962  
U.S. Navy - Office of Naval Research  
Grant N00014-93-0686

### Project Staff

Christoforos N. Hadjicostis, Professor George C. Verghese

The traditional approach towards fault-tolerant computation has been modular redundancy. Although universal and simple, modular redundancy is inherently expensive and inefficient in its use of resources. Recently developed algorithm based fault tolerance (ABFT) techniques offer more efficient fault coverage, but their design is specific to each application. A particular class of ABFT techniques involves the design of arithmetic codes that protect elementary computations. For the case of computations that can be represented as operations in a group, the doctoral thesis by Beckmann<sup>6</sup> has shown how to obtain a variety of useful results and systematic constructive procedures.

In our research so far, we have been able to generalize this work to the case of computations occurring in semigroups and semirings<sup>7</sup> and to outline a procedure that reflects such algebraically-based ABFT

6 P.E. Beckmann, *Fault-Tolerant Computation Using Algebraic Homomorphisms*, RLE TR-580 (Cambridge, Massachusetts: MIT Research Laboratory of Electronics, 1993).

7 C.N. Hadjicostis, *Fault-Tolerant Computation in Semigroups and Semirings*, RLE TR-594 (Cambridge, Massachusetts: MIT Research Laboratory of Electronics, 1995).

design into hardware. Currently, we are exploring extensions of our approach to sequences of computations associated with the evolution of dynamic systems in particular algebraic settings, such as linear systems over groups, or rings, or semirings, or finite automata and discrete-event systems. Along these lines, we have obtained an illuminating characterization of all possible redundant linear time-invariant (LTI) state-space embeddings of a given LTI state-space model. We have also illustrated a method of constructing fault-tolerant finite automata using a combination of group and semigroup homomorphic mappings. In our future work, we intend to fold probabilistic models for failures and errors into the design and analysis of ABFT systems.

## 1.9 Estimation and Equalization of Wireless Fading Channels

### Sponsors

National Science Foundation Graduate  
Research Fellowship  
National Science Foundation  
Grant MIP-9502885  
U.S. Navy - Office of Naval Research  
Grant N00014-93-1-0686  
Grant N00014-96-1-0930

### Project Staff

Nicholas J. Laneman, Professor Gregory W. Wornell

A central issue in the wireless communications setting is the problem of signal fading. Due to multiple propagation paths, many copies of the transmitted signal arrive at the receiver antenna, each with a given attenuation level and phase shift. When the receiver antenna is set in motion, as is usually the case in such applications as cellular telephony, the received power level fluctuates since the multipath components add constructively or destructively. Because of this fading characteristic, wireless channels exhibit dramatically poorer bit-error performance than traditional additive white Gaussian noise channels when using uncoded transmissions.

Recent work<sup>8</sup> has suggested a technique known as spread-response precoding for combating signal fading found in wireless links. The idea behind this sort

of precoding is to distribute the energy of each symbol in time to achieve the average effect of the channel rather than the instantaneous fade. A key element of the receiver is an equalizer which essentially inverts the effect of the fading channel. In our present work, we focus on a realistic equalizer structure derived from channel estimates.

We are evaluating a joint state and parameters estimator for the channel response based on Kalman filtering ideas and the Estimate Maximize (EM) algorithm. We are studying how to use estimates of the channel or channel inverse to best equalize the received signal and how to take advantage of the special properties of the transmitted signal to allow the algorithm to perform blindly.

A flexible set of hardware has been assembled for demonstrating a variety of these signal processing algorithms indoors. Special purpose analog hardware has been built for modulating baseband signals to radio frequencies and back. The laboratory includes digital-to-analog (D/A) and analog-to-digital (A/D) converters for converting the baseband signal into discrete-time. Finally, four digital signal processors (DSPS) are used to perform the precoding and equalization of the baseband signals. The high computational power of the DSPS allow us to implement complex algorithms in real-time.

## 1.10 Distributed Signal Processing

### Sponsors

AT&T Bell Laboratories  
Graduate Research Fellowship  
U.S. Air Force - Office of Scientific Research  
Grant F49620-96-1-0072  
U.S. Army Research Laboratory  
Contract DAAL01-96-2-0001  
U.S. Navy - Office of Naval Research  
Grant N00014-93-1-0686

### Project Staff

Li Lee, Professor Alan V. Oppenheim

This research explores issues arising from designing digital signal processing algorithms for dynamically-varying computing environments such as an unreli-

8 G.W. Wornell, "Spread-Response Precoding for Communication over Fading Channels," *IEEE Trans. on Info. Theory* 42(2): 488-501 (1996); G.W. Wornell, "Spread-Signature CDMA: Efficient Multiuser Communication in the Presence of Fading," *IEEE Trans. Info. Theory* 41(5): 1418-38 (1995).

able network of processors. We present a language for specifying signal processing algorithms which permits the execution path of the algorithm to be dynamically chosen. The language leads naturally to a graphical representation of the algorithm with interesting interpretations. Finally, we formulate and characterize the solution for the problem of dynamically and optimally choosing the execution path of algorithms to minimize a system-wide cost function such as expected congestion.

### **1.11 Transmit Antenna Arrays for Multiple-User Wireless Communication**

#### **Sponsor**

National Science Foundation  
Grant MIP 95-02885

U.S. Navy - Office of Naval Research  
Grant N00014-93-1-0686  
Grant N00014-96-1-0930

U.S. Army Research Laboratory  
Contract DAAL01-96-2-0002

#### **Project Staff**

Michael J. Lopez, Professor Gregory W. Wornell

In wireless communication, a signal can reach a destination in different ways by reflecting off buildings and other obstacles. Multipath fading, caused by interference when two or more such rays combine at the receiver, is thus a major issue. One method of combating fading is with diversity, by inserting redundancy in different time, frequency, or spatial slots. We have been investigating spatial diversity using multiple antennas at the transmit side.

Certain strategies have been proposed in the literature when the transmitter does not know the channel properties, is broadcasting to all possible receivers, or is communicating with one user on a known channel. We are studying the case where the transmitter attempts to communicate along known channels to a finite number of receivers. We have looked at some of the inherent tradeoffs involved in the problem and have calculated performance measures for a few potential algorithms. It is interesting to look at the unknown channel or broadcast scenarios as asymptotic cases of this as the number of receivers becomes large and to compare the advantages of using broadcast versus multicast strategies when the number of users is moderate.

We are also interested in opportunities to exploit other kinds of diversity and in the various duality-type relationships that exist between different kinds of diversity.

### **1.12 Approximate Signal Processing**

#### **Sponsors**

Sanders, a Lockheed-Martin Corporation  
Contract BZ4962

U.S. Army Research Laboratory  
Cooperative Agreement DAAL01-96-2-0001

U.S. Navy - Office of Naval Research  
Grant N00014-93-1-0686

#### **Project Staff**

Jeffrey T. Ludwig, Dr. Hamid S. Nawab

Techniques for reducing power consumption in digital circuits have become increasingly important because of the growing demand for portable multimedia devices. Digital filters, ubiquitous in such devices, are a prime candidate for low-power design. We present a new algorithmic approach to low-power frequency-selective digital filtering which is based on the concepts of adaptive approximate processing. This approach is formalized by introducing the class of approximate filtering algorithms in which the order of a digital filter is dynamically varied to provide time-varying stopband attenuation in proportion to the time-varying signal-to-noise ratio (SNR) of the input signal, while maintaining a fixed SNR at the filter output. Since power consumption in digital filter implementations is proportional to the order of the filter, dynamically varying the filter order is a strategy which may be used to conserve power.

We construct a framework to explore the statistical properties of approximate filtering algorithms and show that under certain assumptions, the performance of approximate filtering algorithms is asymptotically optimal. We investigate the transient effects of dynamically varying the order of a digital filter by developing deterministic and probabilistic frameworks for state transition error analysis. Approximate filter structures using FIR and IIR digital filter constituent elements are explored and shown to be an important element in the characterization of approximate filtering algorithms. Experiments involving speech signals are used to demonstrate the practical viability of approximate filtering algorithms in the context of low power signal processing.

### 1.13 A Framework for Low-Complexity Communication Over Channels with Feedback

#### Sponsor

U.S. Navy - Office of Naval Research  
Grant N00014-93-1-0686  
Grant N00014-96-1-0930

#### Project Staff

James M. Ooi, Professor Gregory W. Wornell

Our research develops a framework for low-complexity communication over channels with feedback. In this framework, which is referred to as the compressed-error-cancellation framework, data are sent via a sequence of messages: the first message contains the original data; each subsequent message contains a source-coded description of the channel distortions introduced on the message preceding it. The usefulness and flexibility of the framework is demonstrated by applying it to a number of fundamental feedback communication problems.

The framework is first used for coding over known single-user channels. For discrete memoryless channels with complete, noiseless feedback (DMCfs), a coding scheme exploiting low-complexity lossless source coding algorithms is developed, and the associated encoder and decoder are shown to use a number of computations growing only linearly with the number of channel inputs used (linear complexity). The associated error exponent is shown to be optimal in an appropriate sense and implies that capacity is achievable. Simulations confirm the analytically predicted behavior. For the class of channels with memory known as discrete finite-state channels with complete, noiseless feedback (DFSCfs), the framework is used to develop linear-complexity coding schemes performing analogously in terms of rate and reliability to the schemes developed for DMCfs.

The framework is then used for coding over unknown DFSCfs with complete, noiseless feedback. A linear-complexity universal communication scheme whose rate varies with the quality of the realized channel is developed and analyzed. The asymptotic rate and reliability characteristics of this universal scheme are shown to be similar to those of the schemes developed for known channels.

An extension of the compressed-error-cancellation framework is developed for discrete memoryless multiple-access channels with complete, noiseless feedback and leads to linear-complexity coding schemes achieving rates on the frontier of the feedback-free capacity region.

Finally, the compressed-error-cancellation framework is applied to the problem of coding for channels with noisy and partial feedback. The scheme developed for DMCfs is modified to incorporate Slepian-Wolf coded feedback, resulting in a linear-complexity, capacity-achieving coding scheme with partial, noiseless feedback. This modified scheme, of which the ARQ protocol is shown to be a special case, is then used as an outer code in a concatenated coding arrangement; with a forward error-correcting (FEC) code used as the inner code, a framework emerges for integrating FEC coding with feedback coding, leading to a broad class of coding schemes using various amounts of noiseless feedback. Preliminary investigation on partial-feedback multiple-access scenarios and noisy feedback scenarios are also discussed.

### 1.14 Analysis and Applications of Systems Exhibiting Stochastic Resonance

#### Sponsors

U.S. Air Force - Office of Scientific Research  
Grant F49620-96-1-0072  
U.S. Navy - Office of Naval Research  
Grant N00014-93-1-0686  
U.S. Army Research Laboratory  
Contract DAAL01-96-2-0002

#### Project Staff

Haralabos C. Papadopoulos, Professor Gregory W. Wornell

Stochastic resonance is a phenomenon encountered in certain nonlinear systems when driven by noisy information-bearing signals. Specifically, increasing the input noise level in these systems often results in an enhancement of the information-bearing signal response, reflected for example, as output signal-to-noise ratio (SNR) enhancement, or as improved detection/estimation performance. Such systems are therefore appealing candidates for use in a variety of engineering contexts. In terms of signal analysis, such systems constitute potentially useful models for

natural phenomena such as the regularity of appearance of earth's ice ages,<sup>9</sup> as well as for detection mechanisms in certain species, such as predator sensing by crayfish.<sup>10</sup> In terms of signal synthesis, the induced signal enhancement renders them attractive in a number of applications in signal communication and processing. In order to exploit stochastic resonance in such applications, there is a need for tools to analyze these systems in the presence of various forms and degrees of distortion.

One of the main directions of the proposed thesis is toward the development of novel techniques for analysis of dynamical systems exhibiting stochastic resonance and considering their viability in various signal processing and communication contexts. In addition, the thesis explores the phenomenon of stochastic resonance in the context of general signal processing problems which includes signal detection, classification, and enhancement.

### **1.15 Linear Models for Randomized Sampling of Discrete-Time Signals**

#### **Sponsor**

U.S. Army Research Laboratory  
Grant DAAL01-96-2-0001

#### **Project Staff**

Maya R. Said, Professor Alan V. Oppenheim

Efficient computation in digital signal processing is a practical problem that has been approached in various ways. Traditional solutions involve down-sampling the signal by a constant factor. Instead, in this project we explore the use of randomized sampling of the discrete-time signal as a method for reducing multiplications in the convolution sum. We have designed several algorithms based on randomized sampling of the input signal, the system function, and also iterative randomized sampling of the system function. In addition, we have formulated additive noise models for each algorithm which allowed linear filtering techniques to be applied.

### **1.16 Modeling and Design of Approximate Digital Signal Processors and Approximate DSP Networks**

#### **Sponsors**

U.S. Army Research Laboratory  
Cooperative Agreement DAAL01-96-2-0001  
U.S. Navy - Office of Naval Research  
Grant N00014-93-1-0686

#### **Project Staff**

Matthew J. Secor, Professor George C. Verghese, Professor Hamid S. Nawab, Professor Alan V. Oppenheim

This research investigates the area of approximate digital signal processing, studying the interactions among and collective performance of multiple approximate processors or processes. The approach we take is to study networks of digital signal processing (DSP) modules whose parameters and functionality can be varied to adapt to changes in specifications and constraints. We focus on specifications that provide metrics or tolerances for various features of input and output quality such as time- and frequency-resolution, quantization, and probability of error, thus allowing the individual DSP modules to carry out as approximate processing. The flexibility allowed by approximate processing can be critical to accommodating constraints placed on a system comprised of approximate processors. The constraints of interest involve such resources as cost, time, power, memory, and inter-processor communication. Our research includes modeling, the development of resource allocation and scheduling schemes, and simulation/testing. Another major area of our research is the development of new DSP algorithms and modification of existing DSP algorithms such that they exhibit incremental refinement properties and thus can be incorporated into larger approximate processing systems.

9 R. Benzi, A. Sutera, and A. Vulpiani, "The Mechanism of Stochastic Resonance," *J. Phys. A* 14: L453-57 (1981).

10 J.K. Douglass, L. Wilkens, E. Pantazelou, and F. Moss, "Noise Enhancement of Information Transfer in Crayfish Mechanoreceptors by Stochastic Resonance," *Nature* 365: 337-40 (1993).



## 1.17 Sinusoidal Analysis Synthesis

### Sponsors

Sanders, a Lockheed-Martin Corporation  
Contract BZ4962

U.S. Air Force - Office of Scientific Research  
Grant F49620-96-1-0072

U.S. Navy - Office of Naval Research  
Grant N00014-93-1-0686

### Project Staff

Alan J. Seefeldt, Professor Alan V. Oppenheim

In our research, the use of sinusoidal analysis/synthesis (SAS) for the enhancement of noise corrupted speech is being explored. SAS approximates a digital speech waveform as a finite sum of time varying sinusoidal tracks. For the purposes of enhancement, the idea is to extract from the spectrum of the corrupted speech sinusoidal tracks that correspond to the speech alone. In order to attain an upper bound on the performance of SAS enhancement, the original uncorrupted speech is used as an aid in this track extraction procedure. Various processing techniques, such as spectral subtraction and amplitude smoothing, are then applied to the extracted tracks to reduce any remaining noise residual. The quality of speech enhanced with this SAS technique is being compared to that of previously developed enhancement procedures.

## 1.18 Speech Enhancement with Side Information

### Sponsors

Sanders, a Lockheed-Martin Corporation  
Contract BZ4962

U.S. Army Research Laboratory  
Contract DAAL01-96-2-0001

U.S. Navy - Office of Naval Research  
Grant N00014-93-1-0686

### Project Staff

Charles K. Sestok, Professor Alan V. Oppenheim

Common approaches to noise reduction in speech signals use only statistical information about the signal. In some cases, more accurate characterizations of the clean speech exist. For example, a communications system consisting of a noisy analog channel and a low bandwidth digital channel could transmit a

complete but corrupted version of the speech on the analog link and an error free side information signal on the digital link. This research examines the performance achievable by employing such deterministic information about the original speech waveform.

Since spectral shaping parameters provide a good model for speech, linear prediction (LP) coefficients and zero phase impulse response coefficients were considered as side information. Experiments were performed using both sets of side information to enhance speech corrupted with additive white Gaussian noise. An approximate maximum likelihood (ML) estimator for the original speech using the LP side information and an exact ML estimator using the zero phase impulse response coefficients have been implemented. Both algorithms were able to reduce the audible noise at signal-to-noise ratios of 0 dB. Future directions for this research include comparison of the results with other noise cancellation procedures and extensions of the algorithm to single channel scenarios.

## 1.19 Communications Using Chaotic Systems

### Sponsors

Sanders, a Lockheed-Martin Corporation  
Contract BZ4962

U.S. Air Force - Office of Scientific Research  
Grant F49620-96-1-0072

U.S. Army Research Laboratory  
Contract DAAL01-96-2-0001

### Project Staff

Wade P. Torres, Professor Alan V. Oppenheim

Chaotic systems have special properties that are potentially useful for communications. We are exploring three directions within this context: transmitter/receiver design, noise reduction, and analog source encoding. With transmitter/receiver design, certain chaotic systems can be synchronized through a weak, one-way coupling, chaotic signals are broadband and the chaotic signals are noise-like and difficult to predict. The synchronization property opens up many possibilities for chaotic transmitter/receiver designs, and the broadband property makes chaotic signals natural candidates as modulation waveforms for spread spectrum communications. Several schemes have been proposed for chaotic communication systems, and some of the difficulties encoun-

tered were maintaining synchronization in the presence of both noise and parameter mismatch between the transmitter and receiver, implementation issues relating to the sensitivity with respect to parameter mismatch, and finding methods of embedding the information signal in such a way that it is not easily extracted by an unintended listener. We are exploring new approaches that avoid these difficulties. Because much of the difficulties are rooted in synchronization, we are particularly interested in chaotic communication systems that do not require synchronization. We have also been exploring the use of chaotic systems for noise reduction. In this context, the useful property of chaotic systems is the sensitive dependence on initial conditions. A third direction that we are exploring is based on the approach to analog error correcting codes based on chaotic maps first proposed by Chen and Wornell. Using the tent map, they have shown that these codes outperform linear modulation codes and M-ary digital codes in a range of power-bandwidth regimes.

### **1.20 Parameter Estimation for Autoregressive Gaussian-Mixture Processes**

#### **Sponsors**

U.S. Air Force - Office of Scientific Research  
Grant F49620-96-1-0072

U.S. Army Research Laboratory  
Contract DAAL01-96-2-0001

U.S. Navy - Office of Naval Research  
Grant N00014-93-1-0686

#### **Project Staff**

Shawn M. Verbut, Professor Alan V. Oppenheim

This research addresses the problem of estimating parameters of discrete-time non-Gaussian autoregressive (AR) processes. The subclass of such processes considered has been restricted to those whose driving noise samples are statistically independent and identically distributed according to a Gaussian-mixture probability density function (pdf). Because the likelihood function for this problem is typically unbounded in the vicinity of undesirable, degenerate parameter estimates, the maximum likelihood approach cannot be used. Hence, an alternative approach has been taken whereby a finite local maximum of the likelihood surface is sought. This approach, which is termed the quasi-maximum likelihood (QML) approach, has been used to obtain esti-

mates of the AR parameters as well as the means, variances, and weighting coefficients that define the Gaussian-mixture pdf. A technique for generating solutions to the QML problem has been derived using a generalized version of the expectation-maximization principle. This technique, which is referred to as the EMAX algorithm, has been applied in several illustrative cases; its performance in these cases has been favorable to that of previously proposed algorithms based on the same data model and to that of conventional least-squares techniques.

### **1.21 Array Processing Techniques for Broadband Mode Estimation**

#### **Sponsor**

U.S. Navy - Office of Naval Research  
Grant N00014-95-1-0362

#### **Project Staff**

Kathleen E. Wage, Professor Arthur B. Baggeroer

Normal mode representations are useful in many aspects of underwater acoustics, e.g., modal acoustic tomography uses precise measurements of the travel time of broadband pulses to invert for environmental parameters. Typically, acoustic modes are used for describing and analyzing the temporal and spatial structure of narrowband signals, and previous work has focused primarily on mode estimation algorithms for CW sources. The objective of this research is to develop an array processing framework for estimating the modal composition of broadband receptions and to use that framework to explore the time/frequency resolution tradeoffs inherent in the processing of transient mode arrivals. Since the modal wave numbers vary with frequency, the modes have frequency-dependent spatial distributions (mode-shapes) and are temporally-dispersive. This thesis considers both of those issues in addressing two related signal processing problems: modal beamforming and mode arrival detection.

Modal beamforming is the estimation of a time series of modal excitation coefficients based on measurements from a hydrophone array. Performance of conventional mode estimators is directly linked to how well the hydrophone array samples the water column. This research program focuses on developing robust techniques which will mitigate the sensitivity to single-sensor failures and aid in the design of shorter arrays with minimal loss in resolution capabilities. Mode estimation is closely related to adaptive beam-

forming and linear inverse theory, thus the results of this research may be relevant to a broader class of signal processing problems. The second area of concentration is the detection of broadband pulse arrivals in the acoustic modes and the estimation of the associated travel times. Although numerous researchers have proposed using modal group delay perturbations for tomographic inversions, very few have examined the signal processing required to determine the arrival times. An objective of the proposed research is to develop optimal receivers for the modal signals and to characterize their performance. The receiving strategies must account for the dispersive nature of the ocean waveguide and extend to channels that have random coupling and fading due to internal waves.

The effects of internal waves on the coherence of propagating modes is one of the current interesting issues in both matched field processing and acoustic tomography. While much theoretical research has been done on long-range propagation of modes in deep water, there have been few opportunities to compare theoretical predictions with experimental measurements. Deployment of mode-resolving vertical arrays as a part of the acoustic thermometry of ocean climate (ATOC) experiment has provided data sets which may offer insights about mode coherence at long ranges. This thesis examines the modal composition of ATOC receptions using a broadband mode framework based on the short-time Fourier transform.

## 1.22 Multiscale State-Space Algorithms for Processing 1/f Signals

### Sponsors

U.S. Air Force - Office of Scientific Research

Grant F49620-96-1-0072

U.S. Navy - Office of Naval Research

Grant N00014-93-1-0686

### Project Staff

Alex Che-Wei Wang, Professor Gregory W. Wornell

Natural landscapes, noise in electrical devices, and fluctuations in the stock market are among the extraordinary variety of phenomena that exhibit fractal structure. As a result, the need for efficient and robust algorithms for processing fractal signals arises in many engineering contexts.

Our research develops a discrete multiscale state-space representation for an important class of fractal random processes referred to as 1/f processes. We show that this representation satisfies a novel frequency-based characterization for discrete 1/f processes. Using this representation, we develop efficient algorithms for several signal processing problems that have previously had no practical solution, such as prediction.

## 1.23 Publications

### Journal Articles

Buck, J.R., J.C. Preisig, M. Johnson, and J. Catipovic. "Single Mode Excitation in the Shallow Water Acoustic Channel Using Feedback Control." *IEEE J. Oceanic Eng.* 22(2): 281-91 (1997).

Buck, J.R., J.C. Preisig, and K.E. Wage. "A Unified Framework for Mode Filtering and the Maximum A Posteriori Mode Filter." Submitted to *J. Acous. Soc. Am.*

Hadjicostis, C.N., and G.C. Verghese. "Fault-Tolerant Computation in Groups and Semigroups." Submitted to *IEEE Trans. Comput.*

Isabelle, S.H., G.C. Verghese, and S. Venkataraman. "Time-Averages in DC-DC Converters Operating in the Chaotic Regime." Submitted to *IEEE Trans. Circ. Syst.*

Isabelle, S.H., and G.W. Wornell. "Statistical Analysis and Spectral Estimation Techniques for One-Dimensional Chaotic Signals." *IEEE Trans. Signal Process.* 45(6): 1495-506 (1997).

Ooi, J.M., S.M. Verbout, J.T. Ludwig, and G.W. Wornell. "A Separation Theorem for Periodic Sharing Information Patterns in Decentralized Control." *IEEE Trans. Automat. Contr.* 42(11): 1546-49 (1997).

Ooi, J.M., and G.W. Wornell, "Fast Iterative Coding Techniques for Feedback Channels." Submitted to *IEEE Trans. Info. Theory.*

Papadopoulos, H.C., G.W. Wornell, and A.V. Oppenheim. "Signal Encoding from Noisy Measurements using Quantizers with Dynamic Bias Control." Submitted to *IEEE Trans. Info. Theory.*

Singer, A.C. and A.V. Oppenheim. "Circuit Implementations of Soliton Systems." Submitted to *IEEE Trans. Circ. Syst. II: Analog.*

Singer, A.C., A.V. Oppenheim, G.W. Wornell. "Detection and Estimation of Multiplexed Soliton Signals." Submitted to *IEEE Trans. Signal Process.*

Winograd, J., J. Ludwig, H. Nawab, A. Chandrakasan, and A. Oppenheim. "Approximate Signal Processing." *VLSI Signal Process. J.* 15(1-2): 177-200 (1997).

### Conference Papers

Beheshti, S., and G.W. Wornell. "Iterative Interference Cancellation and Decoding for Spread-Signature CDMA Systems." *Proceedings of IEEE 47th Annual International Vehicular Conference*, Phoenix, Arizona, May 4-7, 1997.

Chandrakasan, A.P., and A.V. Oppenheim. "Design and Implementation of Filters for Low Power Applications." *Proceedings of the 1997 Sensors and Electron Devices Symposium*, College Park, Maryland, January 14-15, 1997.

Fiore, P.D. and R.J. Barron. "Low Complexity Signal Processing Using Tree Classifiers." *Proceedings of the 1997 Sensors and Electron Devices Symposium*, College Park, Maryland, January 14-15, 1997.

Lee, L., and A.V. Oppenheim. "Properties of Approximate Parks-McClellan Filters." *Proceedings of ICASSP '97*, Munich, Germany, April 1997.

Ooi, J.M., and G.W. Wornell. "Fast Iterative Coding for Feedback Channels." *Proceedings of the International Symposium on Information Theory*, Ulm, Germany, June 29-July 6, 1997.

Papadopoulos, H.C., and G.W. Wornell. "Distributed Estimation Techniques for Wireless Sensor Networks." *Proceedings of Allerton Conference Communication Control Computing*, Allerton, Illinois, October 1997.

Verbout, S.M., J.M. Ooi, J.T. Ludwig, and A.V. Oppenheim. "Parameter Estimation for Autoregressive Gaussian-Mixture Processes: The Emax Algorithm." *Proceedings of ICASSP '97*, Munich, Germany, April 1997.

Winograd, J.M., and S.H. Nawab. "Probabilistic Complexity Analysis of Incremental DFT Algorithms." *Proceedings of ICASSP 97*, Munich, Germany, April 1997.

### Technical Reports

Lam, W. *Multiscale Methods for the Analysis and Application of Fractal Point Processes and Queues*. RLE TR-614. Cambridge Massachusetts: MIT Research Laboratory of Electronics, 1997.

Ooi, J.M., and G.W. Wornell. *Fast Iterative Techniques for Feedback Channels: Finite-state Channels and Universal Communication*. RLE

TR-615. Cambridge Massachusetts: MIT Research Laboratory of Electronics, 1997.

Ooi, J.M. *A Framework for Low-Complexity Communication over Channels with Feedback*. RLE TR-617. Cambridge Massachusetts: MIT Research Laboratory of Electronics, 1997.

### Theses

Eggen, T.H. *Underwater Acoustic Communication over Doppler Spread Channels*. Ph.D. diss., Department of Electrical Engineer and Computer Science, MIT, 1997.

Laneman, J.N. *Channel Estimation and Equalization for Spread-Response Precoding Systems in Fading Environments*. S.M. thesis., Department of Electrical Engineer and Computer Science, MIT, 1997.

Ludwig, J.T. *Low Power Digital Filtering Using Adaptive Approximate Processing*. Ph.D. diss., Department of Electrical Engineer and Computer Science, MIT 1997.

Ooi, J.M. *A Framework for Low-Complexity Communication over Channels with Feedback*. Ph.D. diss., Department of Electrical Engineer and Computer Science, MIT, 1997.

Seefeldt, A. *Enhancement of Noise-Corrupted Speech Using Sinusoidal Analysis-Synthesis*. S.M. thesis, Department of Electrical Engineer and Computer Science, MIT, 1997.

### Books

Buck, J.R., M.M. Daniel, and A.C. Singer. *Computer Explorations in Signals and Systems*. Upper Saddle River, New Jersey: Prentice Hall, 1997.

Oppenheim, A.V., A.S. Willsky, and S.H. Nawab. *Signals and Systems*. 2nd edition. Upper Saddle River, New Jersey: Prentice Hall, 1997.

## 1.24 Self-Powered Signal Processing

### Sponsors

National Science Foundation  
 Graduate Fellowship  
 U.S. Army Research Laboratory/Advanced Sensors  
 Federated Lab Program  
 Contract DAAL01-96-2-0001

### Project Staff

Professor Anantha P. Chandrakasan, Rajeevan Amirtharajah

Portable systems that depend on batteries have a limited operating life and are prone to failure at inconvenient times. We propose a system shown in Figure 1, consisting of a generator to create a DC voltage, a DC/DC converter to set the voltage to meet the desired performance, and a DSP which performs some computation. The desired voltage is set by the rate at which the DSP is to produce results.

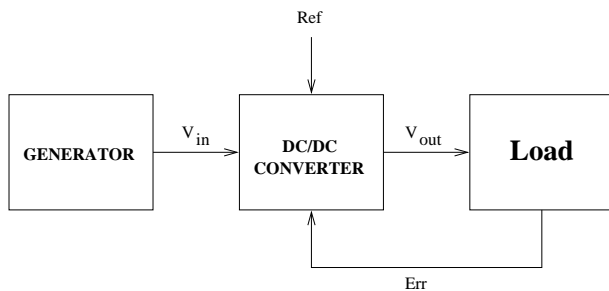

**Figure 1.** System block diagram.

The sources of ambient energy available to the portable or embedded system depend on the application. Examples include light or electromagnetic fields, thermal gradients, fluid flow, and mechanical vibration. A generator based on transducing mechanical vibrations has some distinct advantages: it can be enclosed and protected from the outside environment; it functions in a constant temperature field; and it can be activated by a person (by shaking it, for example). However, it has moving parts and hence less long-term reliability.

Williams and Yates<sup>11</sup> propose an inertial electromechanical generator. This device consists of a mass connected to a spring, the whole mounted within a rigid housing. As the housing is vibrated, the mass moves relative to the housing, and energy is stored in the mass-spring system. A coil is mounted on the mass and moves through a radially directed magnetic field. The time-varying field creates a voltage on the coil, and power can then be extracted from it. The system is damped by mechanical losses and the action of the electromechanical transducer.

To demonstrate the feasibility of a self-powered system, an integrated circuit containing a switching DC/DC converter and an FIR filter was constructed. It was powered by the generator assembly described above. The output of the generator was transformed to a higher voltage that could be rectified by a diode onto a capacitor.

Figure 2 shows the controller feedback loop. The DSP rate command,  $f_{clk}$ , is compared to the VCO output  $f_{vco}$ . The VCO is a ring consisting of the DSP adder critical path padded with a few inverters and is supplied by the regulated output voltage. The converter is a Buck converter with very small P and N FETs (1200  $\mu\text{m}$  and 300 $\mu\text{m}$ ) controlled by a PWM waveform with 6 bit resolution. A new duty cycle is determined from the 2 bit frequency error. The modulated  $V_{in}$  signal is then passed through an LC lowpass filter, external to the chip, to produce  $V_{out}$ , the power supply for the DSP. The FIR filter is a well-known subband filter.

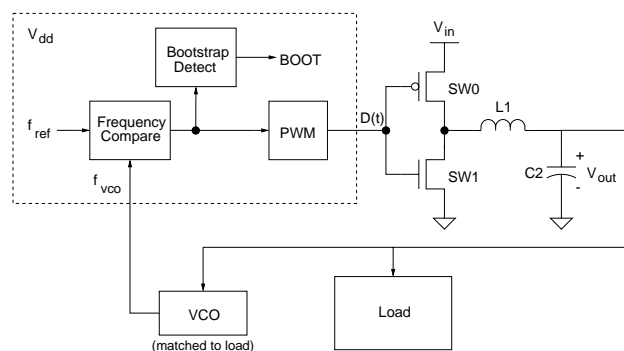

**Figure 2.** Regulator feedback response.

11 C.B. Williams and R.B. Yates, "Analysis of a Micro-Electric Generator for Microsystems," *Proceedings Transducers 95 - Eurosensors 9*, 1995.

Figure 3 shows the regulator loop response to a step change in input voltage.

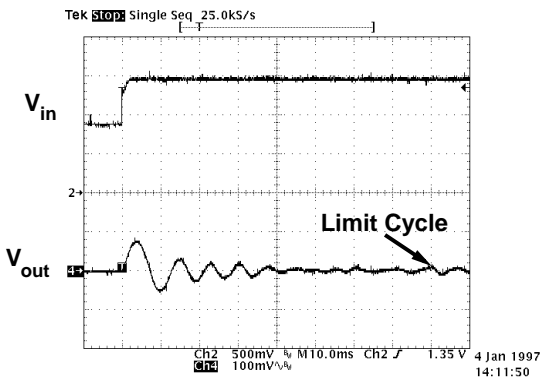

**Figure 3.** Step response.

A die photo is shown in Figure 4.

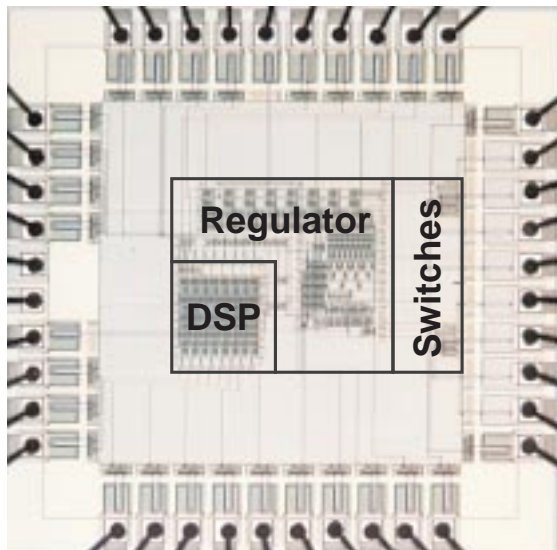

**Figure 4.** Chip die photo.

### 1.24.1 Publication

Amirtharajah, R., and A.P. Chandrakasan. *Self-Powered Low-Power Signal Processing*. Symposium on VLSI Circuits, Kyoto, Japan, June 12-14, 1997.